

ADAMANTIOS I. GAFOS

## A GRAMMAR OF GESTURAL COORDINATION

**ABSTRACT.** Linguistic form is expressed in space, as articulators effect constrictions at various points in the vocal tract, but also in time, as articulators move. A rather widespread assumption in theories of phonology and phonetics is that the temporal dimension of speech is largely irrelevant to the description and explanation of the higher-level or more qualitative aspects of sound patterns. The argument is presented that any theory of phonology must include a notion of temporal coordination of gestures. Linguistic grammars are constructed in part out of this temporal substance. Language-particular sound patterns are in part patterns of temporal coordination among gestures.<sup>1</sup>

### 1. INTRODUCTION

Speaking consists of orchestrating different speech organs in the vocal tract as their movement unfolds in space and time. A widespread assumption in theories of phonology and phonetics is that the temporal dimension of speech is largely irrelevant to the description and explanation of the higher-level or more qualitative aspects of sound patterning. It is assumed that the phonological representation is essentially a linear sequence of segments. Each segment occupies an abstract placeholder, also known as a ‘skeletal slot’ or a ‘timing beat’, in this sequence. However, there is no notion of time in this representation except for the trivial left to right ordering of segments in the sequence, e.g., /p-i-n/. Two skeletal slots or their associated segments cannot overlap with one another. Rather, one skeletal slot

---

<sup>1</sup> I wish to thank three anonymous reviewers for valuable feedback and Michael Kenstowicz for detailed comments which have been extremely helpful in improving this paper. I am grateful to Jeffrey Heath without whose work on Moroccan Arabic and his generous assistance with my questions this work would not have been possible; and to Louis Goldstein for comments on an earlier draft and assistance with the simulations. Discussions with Luigi Burzio, Ioana Chitoran, Mohamed Elmedlaoui, Mohamed Guerssel, Ali Idrisi, and Paul Smolensky are gratefully acknowledged. Thanks are also due to the audiences at Rutgers University, Université du Québec à Montréal, Haskins Laboratories, University of Delaware, City University of New York, Yale University, and the University of Pennsylvania, where parts of this work have been presented, for comments and questions. Research is supported by an NYU Research Challenge Fund, N5006, to the author, and by an NSF grant SBR-951730 to Haskins Laboratories. All errors are mine.



can only follow or precede another. The same applies to the elements within each autosegmental tier. Consider, as a prototypical example, a pre-nasalized stop. In the nasal tier, this consonant is defined by [+nasal] [–nasal], a linear sequence of two non-overlapping autosegments. Indeed, each autosegmental tier consists of what Goldsmith refers to as a ‘segmental level’ or a ‘segmented domain’ with the same formal property of linear sequencing as the skeletal tier (Goldsmith 1976, pp. 25–26).

The ‘segmented domain’ hypothesis consists of the claim that linear order of static units is the only relevant notion of time in phonology. In this paper, I argue instead that the phonologically relevant notion of time is *overlap* of dynamic units. This claim, if true, necessitates a conceptual shift from static autosegments to dynamically defined gestures, like the gestures of Browman and Goldstein (1986 et seq.). In saying that gestures are dynamic, we mean that their state changes in time. As a gesture unfolds, we may identify a set of states or *landmarks* such as onset of movement, achievement of target, and release away from target. These landmarks constitute the *internal temporal structure* of gestures. Gestures enter into *temporal relations* of overlap that refer to these landmarks. Building on these notions, deriving from the model of Browman and Goldstein, this paper argues that linguistic grammars are constructed in part out of this temporal substance.

The paper is organized as follows. After a preview of the argument in section 2, section 3 defines the terms ‘gesture’ and ‘gestural coordination’. Section 4 constitutes the main body of the paper. It argues that a range of properties of Moroccan Colloquial Arabic are lawful consequences of the interaction between constraints on the temporal coordination of gestures and other well-established constraints of phonology. Section 5 discusses alternative schemes for gestural coordination, and section 6 concludes with a summary of the main points.

## 2. CLAIM AND ARGUMENT

The main claim of this paper is that phonological representation includes information about the temporal orchestration of the gestures that constitute consonants and vowels, or, equivalently, (1).

- (1) Main claim (rough formulation)  
Principles or constraints *in the grammar* refer to temporal relations between gestures.

Before previewing the argument for the main claim, I introduce the basic terms that enter into its statement. A gesture is a spatio-temporal unit,

consisting of the attainment of some constriction at some location in the vocal tract. For the purposes of stating orchestration relations, gestures are characterized by a set of dynamical states, here *landmarks*. The landmarks employed in this paper and the sections in which they are introduced are: ONSET, the onset of movement toward the target of the gesture (section 3), TARGET, the point in time at which the gesture achieves its target (section 3), C-CENTER, the mid-point of the gestural plateau (section 3), RELEASE, the onset of movement away from the target (section 3), and RELEASE-OFFSET, the point in time at which active control of the gesture ends (section 4). The set of landmarks available for the statement of temporal relations comprise the internal temporal structure of gestures. Temporal organization is expressed through *coordination relations* between gestures. A coordination relation specifies that some landmark within the temporal structure of one gesture is synchronous with some landmark within the temporal structure of another gesture. The gestural landmarks are depicted in (2a) along with some examples of coordination relations that employ these landmarks.

- (2) Examples of temporal relations ('o' onset, 't' target, 'cc' c-center, 'r' release, 'roff' r offset)

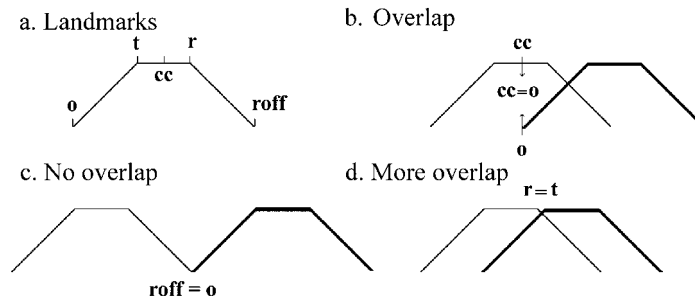

Consider, first, the relation in (2b). In a number of languages and in the relevant environments whose identity is not important in the present context, a sequence of two heterorganic consonants is produced with an intervening acoustic release, also known as an 'open transition' (Bloomfield 1933). For example, in Moroccan Colloquial Arabic (henceforth, MCA), the active participle of the verb 'to write' is [kat<sup>ə</sup>b], with a schwa-like vocalic transition in the final CC cluster. Through computational simulations with a model of gestural dynamics, I show that the temporal relation appropriate for the perceptual result of this transition is the one in (2b). The curves depict a schematic time-course of the oral gestures of the segments involved. The relation in (2b) is such that the *onset* of movement for the lips gesture for /b/ is initiated around the mid-point of the tip-blade gesture for /t/, the *c-center* of /t/ – indicated as 'cc = o'. As a consequence of this relation, the

achievement of the target for the /b/ gesture, lip closure, takes place after the *release* of the /t/ gesture. There is, thus, a period of no constriction in the transition between /t, b/ that is identified as a schwa-like vocalic element.

An independent fact about MCA is that, when two identical consonants must be produced in sequence at the end of a word, the result is also [C<sup>o</sup>C]. For example, the plural of /ZnTiT/ 'tail' is [ZnaT<sup>o</sup>T], where capital letters in the transcription denote pharyngealization (throughout this paper). In terms of the presence of a release, [T<sup>o</sup>T] or [t<sup>o</sup>t] is identical to [t<sup>o</sup>b]. However, a crucial difference underlies these two superficially identical consonant profiles. A [t<sup>o</sup>t] sequence requires a *distinct temporal relation* from that of [t<sup>o</sup>b]. If two identical consonants are timed as in (2b), there will be no acoustic release. In a /t t/ sequence, if the gesture of the second /t/ begins before the release of the first /t/, as (2b) prescribes, the tip-blade articulator is already at its target position, in contact with the denti-alveolar zone. Activating a second /t/ gesture when the tip-blade is already at its target does not result in an acoustic release. Instead, the tip-blade maintains its contact with the denti-alveolar zone throughout the /t t/ sequence, with the perceptual result [tt]. The temporal relation required to produce a release in a /t t/ sequence is depicted in (2c), with the two gestures farther apart than in (2b). Specifically, the gestures must be timed so that the onset of the second /t/ begins at some point late in the release phase of the first /t/, the release offset of /t/, hence 'roff = o'. This timing ensures a period of no tip-blade constriction in the transition between the consonants, hence the acoustic release in [t<sup>o</sup>t].

Thus, two identical consonants in sequence are coordinated as in (2c). In other words, overlap of two identical consonants, as in (2b), is avoided. This fact is formally expressed here as an effect of a gestural version of the Obligatory Contour Principle (OCP; Leben 1973; McCarthy 1979, 1986), which disallows overlap of identical units. Intuitively, to avoid violation of the OCP, the two identical gestures underlying the acoustic outcome [t<sup>o</sup>t] drift away from one another, as shown in (2c).

The coordination relation in (2d) shows a pattern where the articulatory release of the first gesture coincides with the target of the second gesture, 'r = t'. This relation may be employed in languages like English where consonant clusters are produced in 'close transition' (Bloomfield 1933), that is, without an acoustic release of the first consonant in a CC. It will also be argued, however, that this relation is employed for clusters of consonants in certain contexts of MCA (sections 3 and 4).

After these examples of temporal relations, we may return to the argument for the main claim of this paper. This argument derives from a range

of phenomena that reveal the phonological relevance of distinct temporal relations between gestures. I preview the argument from two such phenomena, template satisfaction and geminate (in-)separability, each discussed in detail later in this paper.

**Template satisfaction.** The primary characteristic of word-formation in non-concatenative morphology is that the words of any given morphological category conform to a shape invariant, called the *template*. For example, in MCA, diminutives of adjectives employ the template /CCiCC/, hence /Hməq/ ‘crazy’, /smin/ ‘fat’ have the diminutives [Hmim<sup>ə</sup>q] and [smim<sup>ə</sup>n]. Templates offer an ideal context for studying temporal relations between segments. Note that whereas in /smin/, the consonants /m/, /n/ are separated by a vowel, they are contiguous in the diminutive. This re-ordering and placing of segments under strict succession, a hallmark of templates, is methodically exploited here to reveal phonological sensitivity to characteristic temporal relations between segments. In this preview, I focus on temporal relations in final CC clusters within templates (initial and medial clusters are also studied).

As will be established in section 4, MCA templates exhibit a systematic avoidance of the relation in (2c). One source of evidence for this derives from the effects of speech rate on the transitional release between consonants. It is shown that increasing speaking rate affects gestural kinematics in such a way that the acoustic release (in the transition from one consonant to another) disappears, but only if the two consonantal gestures are coordinated as in (2b), not as in (2c). Since the release between two final, heterorganic consonants disappears in fast speech in MCA, this enables us to infer that the default coordination relation employed for template-final CC clusters is (2b) and not (2c). Recall now that the non-overlapped relation in (2c) is observed in words like [ZnaT<sup>ə</sup>T] ‘tails’, where two identical consonants from the base /ZnTiT/ ‘tail’ are brought into contiguity in the derived plural, because of the plural’s template /CCaCC/. The release in [ZnaT<sup>ə</sup>T] persists, even in fast speech. As discussed, the choice of relation (2c) for [T<sup>ə</sup>T] in [ZnaT<sup>ə</sup>T] can be seen as an OCP effect, that is, as a means of avoiding the OCP violation that would result if the two identical consonants were coordinated with the default, overlapped scheme (2b).

It can be shown further that even though the non-overlapped scheme (2c) is attested, it is actively avoided in MCA templates, even if its avoidance implies deviance from a phonological norm. To illustrate, recall the diminutive of /smin/ ‘fat’, [smim<sup>ə</sup>n]. The shape invariant /CCiCC/ on the diminutive is satisfied by duplicating the medial consonant. In particular, the diminutive is not \*[smin<sup>ə</sup>n]. A final [n<sup>ə</sup>n] sequence is avoided. This

could reflect a preference for filling templatic positions by duplicating the medial rather than the final consonant. But this is not the correct interpretation. When the base contains two separate but identical consonants, as in /rq<sup>1</sup>iq<sup>2</sup>/ ‘thin’, the diminutive is [rq<sup>1</sup>iy<sup>3</sup>q<sup>2</sup>], not \*[rq<sup>1</sup>iq<sup>1</sup>q<sup>2</sup>]. In other words, duplication of the medial consonant is avoided when it would result in a [q<sup>3</sup>q] sequence, that is, when it would result in the non-canonical temporal relation required by such [q<sup>3</sup>q] sequences, in (2c). Glide epenthesis is employed instead.

In sum, temporal coordination determines whether the template is satisfied by glide epenthesis or consonant duplication. In the latter case, temporal coordination also determines which consonant is duplicated: medial or edge. Temporal coordination is thus deeply grammatical because it drives template satisfaction in MCA.

**Geminate (in-)separability.** In MCA, templatic word-formation exhibits systematic geminate separability. I illustrate with words from the professional noun /CCaCC-i/, the plural /CCaCC/, and the passive participle /m-CCuC/. The professional noun of /s<sup>w</sup>kkaR/ ‘sugar’ is [skakR-i] ‘dealer in sugar’, the plural of /fddan/ ‘field’ is [fdad<sup>3</sup>n], and the passive participle of /kübb/ ‘pour’ is [m-kbub]. In each case, two consonant positions in the derived form are occupied by the two ‘halves’ of a base geminate, with an intervening vowel. This is *geminate separability*.

Recall now that final consonant clusters in MCA templates are produced with an intervening vocalic element, a release, as in /tqüb/ ‘puncture’ → [taq<sup>3</sup>b] (active participle), /ngür/ ‘pester’ → [t-nag<sup>3</sup>r] (reciprocal), /nimiru/ ‘number’ → [nwam<sup>3</sup>r] (plural). The crucial point concerns the behavior of geminate-final bases mapped to templates with a final CC cluster. In this case, base geminates never separate into two halves with an intervening release. For example, /kübb/ ‘pour’ → [kabb] (active participle), but not \*[kab<sup>3</sup>b], /šəmm/ ‘smell’ → [t-šamm] (reciprocal), but not \*[t-šam<sup>3</sup>m], and /mxadd-a/ ‘pillow’ → [mxadd] (plural), but not \*[mxad<sup>3</sup>d]. This is *geminate in-separability*.

The generalization is that geminates do separate when an intervening vowel is present, /kübb/ → [m-kbub], but not when the intervening element is a release, /kübb/ → [kabb], not \*[kab<sup>3</sup>b]. The latter part of this generalization illustrates the avoidance of the temporal relation required for a release between two identical consonants. This is the ‘non-overlapped’ relation of (2c), a crucially different relation from the default ‘overlapped’ relation of (2b). The other part of the generalization is that geminates separate across true vowels. The sequence [bub], in [m-kbub], poses no challenge to proper coordination. The two consonants are not directly tem-

porally related with each other across the vowel. Rather, each /b/ bears its own temporal relation to the vowel.

In sum, temporal coordination determines geminate (in-)separability. A crucial part of establishing this claim in detail also involves the demonstration that the familiar a-temporal approaches to geminate integrity are untenable for the cases of the phenomenon identified in this paper.

### 3. GESTURES AND GESTURAL COORDINATION

The main claim of this paper is that temporal coordination relations among gestures are phonologically relevant. To express this claim in precise terms, I build on a version of the gestural model developed by Browman and Goldstein (1986, 1995). This model provides us with explicit, formal characterizations of the two key concepts needed here, gestures and gestural coordination.

#### 3.1. *Gestures*

A gesture is a *dynamically* defined, *spatio-temporal* unit. I discuss briefly each of these aspects of a gesture: spatial, temporal, and dynamically defined, in that order. A gesture has spatial dimensions. This derives from the fact that gestures consist of the formation of a constriction, also known as the target, by some articulator at some place in the vocal tract. A set of parameters, called *vocal tract variables*, specify the spatial goals of that constriction. This specification consists of the ‘articulator set’ employed in producing the constriction, the constriction location (CL), and the constriction degree (CD). For example, a gesture involving the tongue body (TB) is parametrized by the values of two vocal tract variables: the constriction location, CL or TBCL, and the constriction degree, CD or TBCD (e.g., for /i/, CL and CD take the values {palatal} and {narrow}).

Gestures contrast on the basis of their tract variables. The CD variable, for example, takes on a range of values with five categorical distinctions: [closed], [critical], [narrow], [mid], and [wide]. The first two values correspond to the binary feature [ $\pm$ continuant] of Chomsky and Halle (1968), with stops assigned the [closed] value and fricatives the [critical] value. The other three values are used for approximants and vowels. The value [mid] corresponds roughly to the [approximant] category of Catford (1977), but can also serve to provide distinctions of height between vowels. For example, front vowels differing in height may contrast in terms of the three values [narrow], [mid], and [wide] (cf. Clements’ 1991 ‘aperture’ proposal and Lindau 1978). CL specifies the place of the constriction in

the vocal tract. It takes the values of [labial], [dental], [alveolar], [postalveolar], [palatal], [velar], [uvular], and [pharyngeal], based on Ladefoged (1989). CL serves to make the same distinctions in terms of place of articulation as the dependent features of the articulator nodes in feature geometric representations: [ $\pm$ anterior], [ $\pm$ distributed], [ $\pm$ back], etc. (see Sagey 1986; Halle 1983).

Gestures also have a temporal dimension. Consider a gesture unfolding in time. There are a few key points that we may identify during the movement of a gesture. First, there is the *onset of movement*, the point in time when the articulator begins to move towards its specified target. Second, as the articulator progressively approaches its target, at some point it attains it. This point in time is the *achievement of target*. After the constriction is held for some time, the articulator releases the constriction and starts its movement away from the target – the point in time known as the *articulatory release*. These points, which I call *landmarks*, are illustrated in the figure below. The depicted trajectory corresponds to the continuous movement of an articulator such as the tongue tip-blade in space (vertical axis) and time (horizontal axis). The portion of the trajectory between target and release is called the ‘gestural plateau’, and corresponds roughly to the time period when the constriction is actively held. During that time the movement has more or less ceased and the trajectory is relatively flat. The *c-center* is the midpoint of the gestural plateau. One more landmark, the *release offset*, is introduced in section 4.

### (3) Landmarks in gestural life

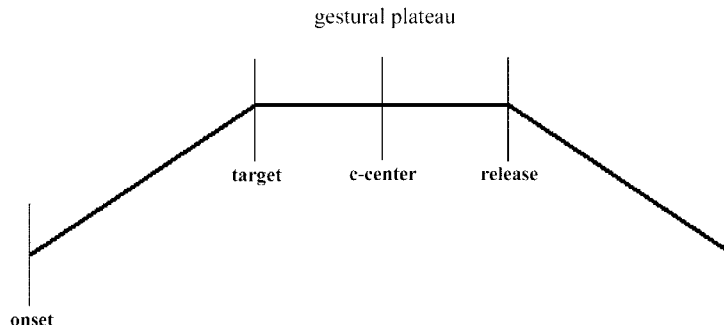

Finally, gestures are *dynamically* defined units. This refers to the mathematical model used to generate the movement of a gesture. Dynamics is the mathematical theory of systems that change over time, also called ‘dynamical systems’ (Abraham and Shaw 1982). The tract variables of a gesture, CL and CD, change value over time and can thus be modeled as dynamical systems. Take, for example, an alveolar stop /d/, with CD =

{clo(sure)}, CL = {alv(eolar)}. The CD tract variable, independent of its initial value, that is, independent of the precise constriction degree the tip-blade happens to have before the onset of movement for /d/, eventually attains its target value which is {clo} or 0 mm (in fact,  $-3.5$  mm is used to model surface compression). It is this continuous change in the value of CD that is modeled as a dynamical system (the same applies to CL). The particular model used is part of a class of dynamical systems that have the property known as *equifinality*. This refers to the fact that regardless of the initial conditions, here the initial values of CD or CL, the system achieves its target value. Gestures in this respect are like other ‘targeting’ movements in living systems with the intrinsic property of being self-equilibrating. Indeed, the mathematical model for gestures derives from a general theory of action and is not, in its underlying principles, particular to speech (Saltzman 1995).

### 3.2. Gestural Coordination

I now review evidence for coordination relations between consonants and vowels. These relations form the basis for a set of coordination constraints to be defined here. These constraints are employed in section 4 as part of a grammar of gestural coordination responsible for a range of phenomena in MCA.

A fundamental aspect of Browman and Goldstein’s gestural model is that the temporal relations among gestures are an explicit part of the representation. An example representation of a simple utterance /p<sup>h</sup>a/ is shown in (4). There are three boxes representing three gestures: the labial closing gesture for /p/, the laryngeal opening gesture for the aspiration, and the tongue body pharyngeal gesture for /a/. Representations like this are called *gestural scores* in Browman and Goldstein’s model.

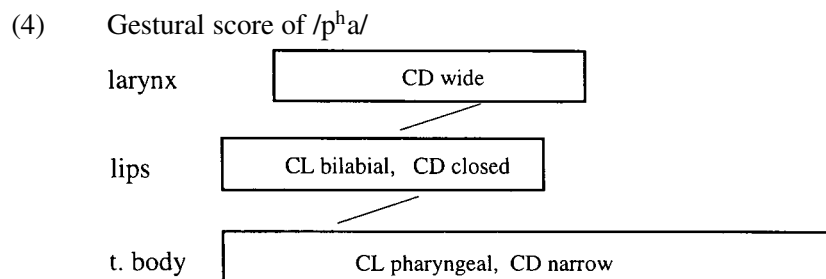

The length of a box indicates the stretch of time during which the tract variables of the corresponding gesture are assumed to be under the active control of the dynamical system. The two lines connecting gestures express

the fact that gestures are temporally organized. This organization or phasing is achieved by synchronizing one landmark in the temporal extent of one gesture with another landmark in the temporal extent of the other gesture. However, the landmark information is not explicitly indicated in the gestural scores of Browman and Goldstein, as in (4) above. For example, the line connecting the lips gesture of /p/ and the tongue body gesture of /a/ is meant as a representation of the fact that the onset of movement of the tongue body gesture coincides with the c-center of the lips gesture. The laryngeal abduction gesture is also related to the labial closing gesture, but now it is the achievement of target of the laryngeal abduction, namely, the attainment of the CD [wide] opening for the larynx, which is synchronized with the release of the labial closure (Kingston 1985).

In the grammatical model of gestural coordination developed herein, the landmark information is crucial. The grammatical statements of coordination relations refer explicitly to landmarks of gestures. Let us then define the term *gestural coordination relation* to mean a relation between two gestures stating that a specified landmark (within the temporal structure) of one gesture is synchronous with a specified landmark of another gesture. Thus, an example of a coordination relation is the statement “in a sequence of two consonant gestures, the achievement of target of the first C gesture is synchronous with the onset of movement of the second C gesture.” The next section demonstrates in detail the coordination relation assumed between two C gestures that plays a crucial role in MCA.

Furthermore, I assume that coordination relations project their corresponding *coordination constraints* into the grammar. Coordination constraints are instantiated using the notion of Alignment, as developed in the Generalized Alignment schema of McCarthy and Prince (1993). The original formulation of alignment is based on a spatial interpretation of that notion. Alignment constraints in general require that edges of morphological or prosodic categories are aligned with the edges of other such categories. In line with the main proposal of this work, the interpretation of alignment I use here is temporal. Two gestures,  $G^1$  and  $G^2$ , are coordinated by specifying the landmarks within the internal temporal structures of the respective gestures to be aligned, here synchronized. By hypothesis, the landmarks available for synchronization are drawn from the following set: onset of movement, attainment of target, c-center, and release or onset of movement away from target (more on this later).

- (5) ALIGN( $G^1$ , landmark<sup>1</sup>,  $G^2$ , landmark<sup>2</sup>): Align landmark<sup>1</sup> of  $G^1$  to landmark<sup>2</sup> of  $G^2$   
 Landmark<sup>i</sup> takes values from the set {ONSET, TARGET, C-CENTER, RELEASE}

- ONSET: The onset of movement toward the target of the gesture
- TARGET: The point in time at which the gesture achieves its target
- C-CENTER: The mid-point of the gestural plateau
- RELEASE: The onset of movement away from the target of the gesture

As is the case with alignment constraints in general, alignment constraints for coordination can be evaluated categorically or gradiently. In categorical evaluation, alignment is either satisfied or violated. In gradient evaluation, quality of alignment is a matter of degree. This degree is measured in units of distance, based on some structural notion specific to the categories aligned. Thus, for prosody, this unit is usually the syllable; for edge-oriented affixation, it is the segment, and so on. In this paper, the unit of temporal distance is defined as the distance between two consecutive landmarks. As a working hypothesis, it is assumed that the temporal distance between the onset-target landmarks and the target-release landmarks is the same,  $\Delta$ . The c-center further divides the plateau between target and release into two halves, each of distance  $\tau = \Delta/2$ . This  $\tau$  will be the minimal unit of temporal distance employed in gradient evaluation of coordination constraints.

I now review the evidence for coordination relations between consonants and vowels. It is well-known that the articulatory movements that constitute consonants and vowels overlap, the ubiquitous ‘coarticulation’. Beyond that, the study of temporal relations among gestures is in its infancy (for reviews see Perkell 1997; Löfqvist 1997; Krakow 1999). One line of research within the area of gestural timing relations is Browman and Goldstein’s work which has addressed, among other things, the gestural basis of syllabic organization. Their work suggests that syllables are characteristic patterns of temporal cohesion among gestures. To say that a set of gestures belong to the same syllable is to say that these gestures enter into a characteristic pattern of temporal organization. Specifically, Browman and Goldstein (1988) have argued that consonants are coordinated with a vowel in a way that depends on their syllabic position. In a cluster like *sp* in [*spats*], the temporal midpoint of the pre-vocalic cluster gives the most stable measure of a relation with the vowel gesture. This point is called the c-center of the consonantal cluster, and it is defined as follows: “for every consonantal gesture, the (temporal) midpoint between the left and right edges of the plateau was computed. The c-center of a sequence is the mean of all the midpoints of the gestures in that sequence” (1988, p. 144).

For coda consonants, the situation is different. Browman and Goldstein report that “the c-center serves to coordinate an initial consonant cluster with the vowel, but for final consonants, it is the achievement of target of the leftmost consonant . . . that is coordinated with the vowel” (p. 150). Browman and Goldstein discuss some remarkable implications of this interpretation of their data that make contact with the asymmetry between onset and coda consonants in bearing weight (Hyman 1985). The reader is referred to the authors’ work for relevant discussion, as well as to Honorof and Browman (1995) and Byrd (1994) who support further the results of Browman and Goldstein using different methods.

Recently, Browman and Goldstein (2001) have proposed that the c-center effect is derived from more basic principles of gestural organization. Their idea is to allow phasing relations between gestures to have ‘bonding strengths’ representing the degree of cohesion of the gestures so related (their terms). This would allow incompatible phase relations to be posited among gestures. For example, in a CCV sequence each onset consonant has a C-V phasing relation with respect to the V. This relation requires that each consonant bears the same phasing relation to the vowel as that of a single consonant in a CV sequence (i.e., the c-center of that single consonant is coordinated with the vowel). In addition, the two consonants have a C-C phasing relation with respect to each other. This relation, Browman and Goldstein propose, requires that the two consonants be coordinated in a way that ensures their recoverability, meaning essentially that the two consonants must not overlap each other completely. In the presence of such conflicting relations, Browman and Goldstein propose that “the temporal pattern that surfaces in the gestural score can be computed as the one that maximizes satisfaction of the competing constraints, as weighted by their bonding strengths”. In particular, they argue that the C-C phasing relation must be ‘stronger’ than the C-V phasing relation, because otherwise the two Cs in a /CCV.../ would completely overlap each other (‘stronger’ not defined). This situation is shown in (6a), where the /s/, /p/ gestures of the intended /speId/ completely overlap each other (TT, TB stand for ‘tongue tip-blade’ and ‘tongue body’, respectively). The vertical line from top to bottom indicates the point of optimal synchronization between a single consonant gesture and the vowel. To optimize the gestural structure, violation of both C-V phasing relations (of /s, p/) must be minimized. The consonants are thus displaced equally in time from the point specified by the C-V phasing relation, see (6b). In other words, the first C gesture slides to the left and the second C gesture slides to the right, equally deviating in opposite directions from the time point that would fully satisfy the C-V relation for a single consonant. Deviations are shown by the horizontal

thick lines. The metric of violation assumed by Browman and Goldstein is the (numerical) mean-squared sum of the individual deviations from optimal C-V phasing. That sum is minimized when the individual violations are equal. This is the pattern of temporal coordination observed in the experimental data.

(6) Hypothetical and actual temporal relations in /speɪd/

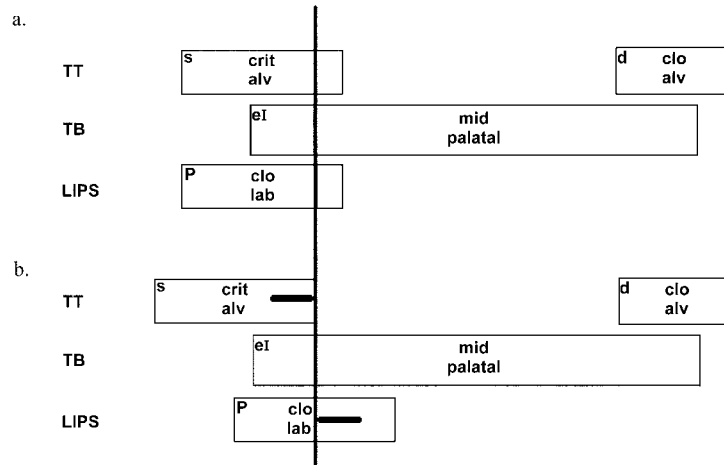

We have thus seen evidence for three types of coordination relations, C-V, V-C, and C-C. The C-V relation holds between each onset consonant and a tautosyllabic vowel. This relation projects its corresponding constraint, CV-COORD(INATION). This constraint requires that the c-center of the C gesture be synchronous with the onset of the V gesture, ALIGN(C, C-CENTER, V, ONSET). Browman and Goldstein attribute the basis of the constraint to a presumed universal property of speech, the parallel transmission of vowels and consonants (see also Liberman et al. 1967). The second coordination relation, V-C, holds between a vowel and the first post-vocalic consonant. By hypothesis, subsequent post-vocalic consonants do not have a V-C coordination requirement (Browman and Goldstein 1988). The V-C relation projects the constraint VC-COORD, which requires that the target of the C gesture is synchronized with the release of the V gesture, ALIGN(V, RELEASE, C, TARGET).

The third relation is C-C. Its role, according to Browman and Goldstein, is to maintain the recoverability of the two consonants by avoiding a degree of overlap which would obscure one or both of the consonants. I depart from Browman and Goldstein here by assuming that the recoverability requirement is different from the default C-C relation in any given language. The main reason for this is that languages show different patterns

of coordination in consonant clusters. For example, Piro has acoustic releases in consonant clusters, but English does not (Matteson and Pike 1958; Anderson 1974). I interpret this to mean that CC-COORD is tailored to different languages. In general, there are two different ways of producing a transition from one consonant articulation to the another, ‘close transition’ and ‘open transition’ (Bloomfield 1933, section 7.9), and these correspond to different coordination patterns. In a close transition “the *articulatory stricture* for the second consonant is formed *before* the stricture for the first is released” (Catford 1988, p. 117; emphasis Catford’s). This requirement may be effected by a CC-COORD stating that the release of the first gesture is synchronous with the target of the second gesture, ALIGN(C<sup>1</sup>, RELEASE, C<sup>2</sup>, TARGET), or with some point after the target such as the c-center of the second gesture. This ensures that there is no acoustic release in a cluster of two consonants coordinated in this way, as in [bd] of English [rabd] ‘robbed’, not [b<sup>o</sup>d]. A similar cluster in MCA, however, is produced with a release, as in [b<sup>o</sup>D] of [bwib<sup>o</sup>D] ‘white (diminutive)’. This open transition is effected through a different coordination constraint, the first topic of the next section.

#### 4. COORDINATION CONSTRAINTS IN MCA PHONOLOGY

The primary goal of this section is to convey the form of a grammar of gestural coordination, and the kinds of linguistic phenomena that such a grammar underlies.

To do so, we study aspects of the phonology of MCA. The sound pattern of a regional dialect of MCA is the subject of a remarkably meticulous study by Heath (1987), henceforth ‘H’. This section focuses narrowly on the templatic word-formation of MCA, for reasons given in section 2. In particular, this section is a study of the coordination relations between consonants at the final (sections 4.1-4.4), initial (section 4.5), and inter-vocalic position (section 4.6), within MCA templates.

##### 4.1. *Final Clusters*

In MCA templates, a word-final sequence of two consonants is produced with a schwa-like vocalic element. For example, the active participles of /ktəb/ ‘write’, /tqüb/ ‘puncture’ are [kat<sup>ə</sup>b] and [taq<sup>ə</sup>b]. The template of active participles is /CaCC/. The plurals of /ZnTiT/ ‘tail’ and /wlsis/ ‘swollen gland’ are [ZnaT<sup>ə</sup>T] and [wlas<sup>ə</sup>s], with the template /CCaCC/, characteristic of a subclass of nouns. This schwa-like vocalic element is present in all derived verbs and participles, in nominal and adjectival plur-

als, and in diminutives (H, p. 343). In this section, the nature of this vocalic element is discussed. It is argued that the “ə” in [C<sup>ə</sup>C] is not an actual vowel gesture, but rather a transition between two consonant gestures. The precise way in which this transition is effected depends on the profile of the consonantal sequence. Specifically, observe that [kat<sup>ə</sup>b] ends in a heterorganic sequence of consonants, but [ZnaT<sup>ə</sup>T] ends in a sequence of identical consonants. In both cases, the acoustic profile of the final CC is the same, [C<sup>ə</sup>C], with respect to the presence of the acoustic release. Despite this similarity, sequences of heterorganic consonants are coordinated differently from sequences of identical consonants. This difference in temporal coordination is important, because it is argued to have a range of salient consequences for the phonology of the language (section 4.2, section 4.3).

#### 4.1.1. *Heterorganic Sequences*

Consider an example of a final sequence of heterorganic consonants. The diminutive of /smin/ ‘fat’, formed on the characteristic diminutive template /CCiCC/, is [smim<sup>ə</sup>n]. Crucially, the “ə” is not present in fast speech (Heath, personal communication, April 2000). Hence, two outputs are possible, [smim<sup>ə</sup>n] and [smimn]. In this section, I begin by first considering the kind of temporal relation between two consonants that would result in this acoustic release. This relation is defined and the term ‘inter-segmental coordination’ is introduced. Then, I show that the proposed view of the “ə” as a transition allows us to model the effect of speaking rate on that vocalic element. This view is then compared to the alternative view of the “ə” as an actual vowel.

Consider the kind of coordination between two consonants that would result in an acoustic release or open transition. In open transition, “the first stricture is *released* a moment before the second stricture is formed” (Catford 1988, p. 118; emphasis Catford’s). A coordination relation that could generate the acoustic release is shown in (7). In this relation, the c-center of C<sup>1</sup>’s oral gesture is synchronous with the onset of C<sup>2</sup>’s oral gesture, that is, ALIGN(C<sup>1</sup>, C-CENTER, C<sup>2</sup>, ONSET). The annotation ‘open vocal tract’ indicates that there is a period of time between the articulatory release of the first gesture and the achievement of the target of the second gesture. This period of time corresponds to the acoustic release that is characteristic of open transition.

$$(7) \quad \text{CC-COORD} = \text{ALIGN}(C^1, \text{C-CENTER}, C^2, \text{ONSET})$$

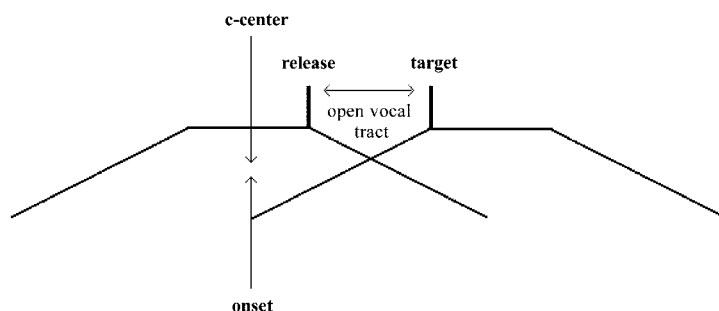

The coordination relation above refers to *gestures*. The MCA facts show releases in final sequences of consonants, as in [t<sup>ə</sup>b], [m<sup>ə</sup>n]. The distinction between ‘consonant’ and ‘gesture’ is important here. In the general case, each consonant consists of a set of gestures. These segment-internal gestures are temporally organized in a characteristic way particular to that segment. For a nasal, the velic opening gesture is coextensive with the oral gesture; for a voiceless [t], the peak opening of the laryngeal abduction gesture is synchronous with the midpoint of the oral gesture. I assume that CC-COORD coordinates *consonants* by reference to their *oral gestures*. In this sense, the oral gesture is the ‘head gesture’ of a segment. Other gestures within each segment, which may be velic or laryngeal, are in turn coordinated with the oral gesture of that segment. This assumption about the ‘head’ status of oral gestures, with respect to coordination in MCA, is justified in the next section. For the moment, the assumption serves to give content to the term *inter-segmental coordination* as defined in (8). This term builds on the notion of gestural coordination introduced earlier. Henceforth, then, we can write  $/C^1 \circ C^2/$  for two consonants coordinated with the coordination relation CC-COORD.

(8) Definition: *Inter-segmental coordination*

Two segments  $S^1, S^2$  are coordinated with some coordination relation  $\lambda, /S^1 \lambda S^2/$ , if the head gestures of these segments are coordinated as in  $\lambda$ .

Now, the figure in (7), but not the grammatical statement of the alignment constraint, may be misleading. I underscore the following important point about coordination relations. It is *not* the presence of an acoustic release that CC-COORD demands. Rather, the coordination relation demands a particular temporal relation that may or may not produce an acoustic release depending on the nature of the two consonants and other parameters such as rate of speech. Note in particular that when two consonants are

identical, *the same coordination relation* shown in (7) does not result in an acoustic release.<sup>2</sup> In /tot/, when the gesture of the second /t/ begins at the c-center of the first /t/, the tip-blade is already at its target, in contact with the denti-alveolar zone. Activating a second /t/ gesture with those initial conditions does not result in an acoustic release. Instead, the tip-blade maintains contact with the denti-alveolar zone throughout the /tot/. This is why I do not state coordination relations and their projected constraints as ‘Have an acoustic release’. A coordination constraint, in other words, specifies a relational invariance between articulatory events that may or may not have the acoustic consequence of a release. Equivalently, coordination constraints are abstract and to a certain extent under-determined by the surface, acoustic information they may generate (more on this later).

I illustrate this property of coordination relations with an example from the Sierra dialect of Popoluca (Zoquean et al. 1947, also Clements 1985). In Sierra Popoluca, transitions between consonants take two forms, open transition and close transition. Open transition is found when “[t]he two members of the cluster are at *different points of articulation*” (Elson 1947, p. 16; emphasis mine). Open transition is manifested as aspiration between voiceless consonants, as in [kɛk<sup>h</sup>. paʔ] ‘it flies’, or as a ‘lenis shwa vowel’ especially after nasals, as in [mij<sup>ə</sup>. paʔ] ‘he comes’. Close transition, defined as “the lack of development of any type of aspiration or shwa vowel”, is observed “[b]etween syllables in which the final consonant of the first and the initial consonant of the second are the *same point of articulation*” (ibid., emphasis mine), as for example in the first CC sequence of [kɛk.gak<sup>h</sup>. paʔ] ‘it flies again’ (/gak/ is a repetitive morpheme). Stop transitions, thus, show surface variability in terms of open or close transition. This variability, however, can be seen to arise from an invariant statement at the level of temporal organization, that is, a relational invariant between gestures like that in (7).

To test the assumptions about presence *versus* absence of a release in CC transitions, and the effect of fast speech on that acoustic release, I employed GEST, a computational model of gestures. There are three modules in GEST. The first is the Linguistic Gestural Model, which takes as input a linear sequence of phonetic characters – the intended utterance – and generates a gestural score, that is, a set of gestures and their coordination relations corresponding to the input phonetic string. This module is particular to American English in that the gestural coordination relations are assumed to be those that are characteristic of American English (Browman and Goldstein 1990a). The second component is the Task Dynamics Model which implements the dynamic modeling of gestures. Using the gestural

<sup>2</sup> I thank Louis Goldstein for pointing this out to me.

score as input, Task Dynamics generates actual articulatory movements corresponding to that gestural score. This module is assumed to be universal. It instantiates a general, mathematical theory of movement in the domain of speech production (Saltzman 1995). The third component, also universal, is the Vocal Tract Model, which generates acoustic output from articulatory movements by using an articulatory synthesizer (Rubin et al. 1981). The computational system that encompasses all three components offers a useful tool for testing hypotheses about gestural organization and its acoustic and perceptual consequences. The system has been used by different researchers for a variety of purposes (e.g., Byrd 1994; Browman and Goldstein 1990b, 1992; Beckman et al. 1992).

Because the Linguistic Gestural Model assumes 'phasing rules' appropriate to English, I modified those rules so that the phasing relation for CC clusters is the CC-COORD relation assumed for MCA, that is, /CoC/. The generated gestural scores were then input to the Task-Dynamic module which computes movement. From movement, the corresponding acoustic waveform was computed, using the Vocal Tract Model. I observed, in full accord with the assumptions, presence of an acoustic release in heterorganic CC sequences, but absence of the release in CC sequences of identical consonants.

Consider now the fact that, at a fast speaking rate, there is no acoustic release in heterorganic final CC clusters. Assume some rate of speech in which gestural execution is faster than some other slower rate. At the faster rate, gestures attain their targets faster and holding and release phases are shorter. In a heterorganic CC sequence, CC-COORD demands that the second gesture begin at the time point corresponding to the c-center of the first gesture. Greater speed of gestural execution means that the time to constriction of the second gesture will be shorter (the gesture's target is achieved faster). We may hypothesize that, beyond a certain level of 'fast speech', the constriction of the second C gesture is achieved fast enough so that there is either a very short period of time or no period of time when no constriction exists in the vocal tract. This would correspond to absence of schwa.

The validity of this hypothesis has also been confirmed with simulations in GEST. In the dynamic model of gestures, the parameter which determines how fast gestures reach their targets is called stiffness. The higher the value of the stiffness, the faster the gesture. Changing stiffness thus can be used to study the acoustic consequences of fast speech, as indeed it has been used in past studies (e.g., Beckman et al. 1992). Maintaining the relational invariance between two consonant gestures – c-center of first to onset of second gesture – I varied the dynamic parameter of

gestural stiffness. It was observed, in full accord with the analysis above, that below a critical value of stiffness an acoustic release is present in the transition between the two consonant gestures; beyond that critical value of stiffness, however, the acoustic release disappears. This fact will be illustrated in (11) later.

Let us sum up the discussion to this point. We have seen that a coordination relation, expressed as a relational invariance between two gestures, can have varied acoustic consequences – the presence or absence of the transitional acoustic release. The precise acoustic consequences of this relation depend on the identity of the consonants so coordinated and on the rate of speech. At a normal speech rate, heterorganic clusters are produced with an acoustic release, but clusters of identical consonants are not produced with an acoustic release. At a faster rate, the acoustic release is not present even in heterorganic clusters. The coordination relation employed in MCA between two identical (and, more generally, homorganic) consonants is discussed in the next section.

Let us now compare this view of the transitional schwa to an alternative view. Heath's analysis of MCA is formulated within an a-temporal model of phonological representations. Naturally, in such a model, the transitional schwa is seen as an actual vowel. This vowel is inserted in the representations via a rule of epenthesis, called Schwa Insertion (H, p. 55). The fact that this schwa is optional is accounted for by positing an optional rule of deletion, called Forward Syncope,  $\text{ə} \rightarrow \emptyset / VC\_C$  (p. 248). As a schematic example of the application of these rules, consider the template /CCaCC/. After mapping of segments to template positions, the rule of Schwa Insertion applies to introduce the final schwa [CCaC<sup>ə</sup>C]. Next, the optional rule of Forward Syncope may apply to give [CCaCC] with no ə. In this view, the vocalic element inserted in the final cluster of a template, henceforth denoted as ə\*, is a short vowel just like the other short vowels of MCA, ə and its rounded version ʊ.

However, consider the following statements that must be part of the grammar of MCA, if this assumption is made. First, Forward Syncope is optional. This statement is needed to account for the fact that both [smimə\*n] and [smimn] are possible. In fact, under fast speech conditions, [smimn] is the output. In our view of ə\* as a transition, this fact receives a straightforward explanation. We saw that changing the dynamic parameter of gestural stiffness affects gestural kinematics so that the open transition between two consonant gestures disappears. In the view of ə\* as a vowel, this corresponds to an application of Forward Syncope which deletes the vowel ə\*. But crucially the effect of fast speech on the applicability of Forward Syncope is not part of the statement of the rule of Forward Syncope.

That speed correlates with application of the rule is an extra-grammatical observation, or at best an annotation to that rule. Indeed, any analysis that assumes ‘open transitions’ to be actual vowels cannot account for this correlation. No principled link exists between such annotations and what the rules do. For example, one can imagine a language where syncope deletes a vowel like ə\* but in slow, not in fast, speech. The fact that such a rule is unintuitive and as far as we know non-existent is a direct consequence of our analysis of the effect of fast speech on open transitions, within the dynamic model of gestures, but must be stipulated in the view of ə\* as a vowel.

Another statement that must be part of the grammar of MCA is that ə\*, the assumed schwa vowel inserted via Schwa Insertion, disappears in fast speech but the short ə vowel does not. Hence, words like /kəbʃ/ ‘ram’, /dhəb/ ‘gold’, /DəHk/ ‘laughter’, /sqəf/ ‘roof’ maintain their schwa vowel in fast speech, when produced in isolation. Heath entertains an analysis where the schwa in CəCC words like /DəHk/ is underlyingly specified, but the schwa in CCəC words like /dhəb/ is epenthetic (H, p. 264). This is orthogonal to the issue at hand. These ə vowels do not delete in fast speech, but ə\* does delete. This fact, too, has a straightforward explanation under our proposal. The key difference between ə\* and ə is that the first is a transition between two consonantal gestures, but the second is a true vowel. Changing gestural stiffness does not eliminate gestures. It only affects their kinematics. The true vowels ə, ʊ are actual gestures. This is why faster speech does not eliminate them.

Finally, consider yet another statement that must be made about Forward Syncope under the view of ə\* as a vowel. Forward Syncope contrasts with another syncope rule, called Backward Syncope, deleting the true short vowels ə, ʊ before a vowel in the following syllable: /kəlb/ ‘dog’, [klb-ək] ‘your dog’, /gləs/ ‘sit’, [glɪs-na] ‘we sat’, /xübz/ ‘bread’, [x<sup>w</sup>bz-na] ‘a loaf of bread’, /kübb/ ‘pour’, [k<sup>w</sup>bb-i-t] ‘I poured’ (when ʊ deletes its rounding surfaces as labialization on the preceding consonant). The key point here is that Backward Syncope treats both short vowels ə, ʊ equally. Backward Syncope is a rule of short vowel deletion. In contrast, Forward Syncope does not treat ə\* and ʊ in the same way. When final /CüC/ sequences are found after a full vowel, Forward Syncope does not apply (H, p. 248). Stems like [axüR] ‘other (masculine.singular)’ and [ka-t-akül] ‘she eats’ do not have surface variants \*[ax<sup>w</sup>R] and \*[ka-t-ak<sup>w</sup>l]. Crucially, there is nothing exceptional about stems like /axüR/ and /akül/, at least as far as the vulnerability of their ʊ to syncope is concerned. These vowels do delete by Backward Syncope: [axüR] ‘other (masculine.singular)’ has the feminine singular form [x<sup>w</sup>R-a] and [ka-t-akül] ‘she eats’ has the

feminine singular form [ta-t-ak<sup>w</sup>l-i] ‘you eat’, where in the feminine forms Backward Syncope applies to delete the ũ. Hence, both short vowels ə, ũ demonstrably delete by Backward syncope, but curiously Forward Syncope must single out one of these vowels. But if ə\* is not a vowel, as we argue, there is no need for such a stipulation. No rule of Forward Syncope exists as part of the grammar of MCA. Its effect has been demonstrated to fall out from the assumption that ə\* is not a vowel gesture, but rather a transition between two consonant gestures. The same holds true for Schwa Insertion. Schwa Insertion inserts the ə\* which may later be deleted by (optional) Forward Syncope. If ə\* is the acoustic consequence of a coordination relation between two consonants, then there is also no need for the rule of Schwa Insertion.

To conclude, the facts reviewed so far provide reasonable support for the proposal that the schwa-like element in final CC clusters of templates is not a vowel but a transition between two consonants. More evidence for this is adduced in the following section.

#### 4.1.2. *Homorganic Sequences*

I now turn to sequences of homorganic consonants, that is, consonants with an identical or similar oral gesture. These are classified into sequences with equal sonority, as in /t, D/, /l, l/, and sequences with different sonority, as in /n, t/, /d, l/. The former show avoidance to overlap, but the latter do not.

4.1.2.1. *Sequences with Equal Sonority.* Just as with heterorganic sequences, sequences of identical consonants at the ends of templates surface with a [C<sup>ə</sup>C] acoustic profile: /ZnTiT/ ‘tail’ → [ZnaT<sup>ə</sup>T] ‘tails’, /wlsis/ ‘swollen gland’ → [wlas<sup>ə</sup>s]. We now know that the coordination relation for [t<sup>ə</sup>t] is not CC-COORD, (7). Coordinating two consonants as required by CC-COORD may have the surface effect of an acoustic release only if the consonants are heterorganic. The same coordination between two consonants with identical oral gestures does not result in an acoustic release. The tongue tip-blade is already at its target position when the second C gesture is initiated. Hence, [t<sup>ə</sup>t] employs a different relation from that of CC-COORD.

Consider now why sequences of identical consonants employ a distinct coordination relation. Coordinating two /t/ gestures as required by CC-COORD (7) implies significant overlap of the two gestures, as “the center of the first C gesture is synchronous with the onset of the second C gesture.” Hence, for identical consonants, CC-COORD enters into conflict with another well-known phonological principle, the Obligatory Contour Principle (OCP; Leben 1973; McCarthy 1979, 1986), stated in (9a). The

version of the principle I propose in (9b) is a direct gestural interpretation of the autosegmental OCP, and it is given here in its most general form. It is well known that languages exhibit OCP effects for particular (sets of) features (Mester 1986; McCarthy 1988; Yip 1989). Such elaborations would directly carry over to the gestural version of the principle. Indeed, as I discuss later, in MCA it is identity between overlapping oral gestures of segments with equal sonority that is prohibited.

- (9) Obligatory Contour Principle
- a. OCP (autosegmental version): **Adjacent** identical elements are prohibited.
  - b. OCP (gestural version, preliminary): **Overlapping** identical gestures are prohibited.

In /t, t/ sequences, the conflict between the OCP and CC-COORD is resolved by separating the two /t/s by a release, [t<sup>ɹ</sup>t]. I now express this conflict formally. The candidates favored by the two constraints at hand are shown in the rows of an Optimality Theory tableau (Prince and Smolensky 1993) in (10). The string in ‘/.../’ stands for a sequence of segments and their coordination relations. These are the entities evaluated by our grammar. Corresponding acoustic outputs, indicating the presence or absence of an acoustic release, are provided next to each candidate in ‘[... ]’. In (10a), the candidate is /tot/, that is, two /t/s coordinated according to CC-COORD. This temporal relation is shown in the corresponding figure (a), where the c-center of the first gesture is synchronous with the onset of the second. The two /t/s overlap. This is a violation of the OCP constraint. In (10b), the candidate is /t<sup>ɹ</sup>t/. The ‘<sup>ɹ</sup>’ is a shorthand for the coordination relation that would result in a release between two identical consonants, [t<sup>ɹ</sup>t]. This relation is shown in figure (b) (ignore the label *release offset* for the moment). This is a different relation from that required by CC-COORD. Hence, candidate (10b) violates CC-COORD. Since candidate (10b) is the reported output, we infer that OCP is ranked higher than CC-COORD, that is, OCP ≫ CC-COORD. Intuitively, to avoid violating the OCP, the two consonants are distanced further apart, with concomitant violation of the canonical coordination relation favored by CC-COORD.

- (10) CVC with identical consonants mapped to a CC cluster: Avoidance of overlap; Inferred ranking: OCP  $\gg$  CC-COORD

Base: /tVt/	OCP	CC-COORD
a. /tot/ [tt]	*!	
b.  /t $\Rightarrow$ t/ [t $\supset$ t]		*

The actual candidate representations, for (10a) and (10b), evaluated by the grammar are as follows.

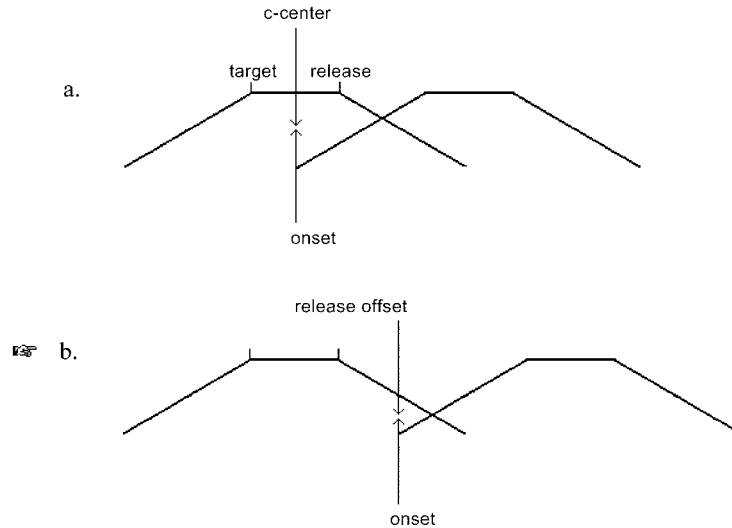

Consider candidate (10b) in more detail. Interestingly, given current assumptions, there is no coordination relation that would generate a release between two identical consonants, as in [t $\supset$ t]. To see this, recall that we have been assuming so far that the landmarks available for synchronization are onset, target achievement, c-center, and articulatory release of a gesture. One way of generating an acoustic release between two /t/s would be to synchronize the latest available landmark in the first gesture, its articulatory release, with the onset of movement of the second gesture. This, however, will not result in an acoustic release between the two /t/s. At the articulatory release of the first gesture, the articulator is still at its target position. If, at that time point, another gesture with the same target is initiated, the tip-blade will remain at its target position, producing an uninterrupted [tt] closure.

Behind our assumption about the set of landmarks made available for stating coordination relations lies another assumption that should be made explicit now. We have been assuming that after the articulatory release, the movement of the articulator(s) away from target follows passively the tend-

ency of the speech organs to return to some neutral position (a common assumption). We now see that this assumption cannot be maintained. The coordination needed to produce an acoustic release between two /t/ gestures is one where the onset of movement of the second gesture coincides with some time point late in the release phase of the first gesture. In figure (10b), I call *release offset* the point when active control of movement away from target of the first gesture ceases. This is the time point which I assume is synchronized with the onset of the second gesture. This coordination ensures that the tip-blade has moved away from its target before movement towards a second identical target begins.

As it turns out, Browman (1994), using simulation studies, has argued that active control of movement away from the target must be part of a gesture's specification just as movement towards the target is actively controlled. The precise dynamic specification of the release component has not been addressed as of yet. What is clear, however, is that a release component must be part of a gesture's specification, and this is all that is needed for our purposes. Indeed, if the release phase of a gesture is actively controlled, then there is a way to state the coordination relation we are after.

Let us now define explicitly the notion of phonological overlap between gestures, employed in the statement of the OCP in (9b). A gesture's active control regime is the interval between the onset of movement and the release offset landmarks. During this interval, the movement of the gesture is actively controlled. Movement may continue after the release offset, due to the articulators' biomechanical inertia or due to movement associated with a different gesture. But such movement is not part of the linguistically-significant goal of the associated gesture. An example of such movement is depicted in figure (10b) by the portion of the curve beyond the release offset of the first gesture. The phonologically relevant notion of gestural overlap proposed here properly applies only to overlap between the active control regimes of two gestures, as in figure (10a). The intersection of the curves depicted in figure (10b) does not imply phonological overlap, since after the release offset of the first gesture, the active control regime of that gesture has ceased.

I now turn to independent evidence in MCA for the crucial distinction posited in the gestural representations underlying [t<sup>3</sup>t] and [b<sup>3</sup>d] sequences. We have inferred that the coordination plan generating a release between two identical consonants, denoted as /t<sup>3</sup>t/, acoustically [t<sup>3</sup>t], must be distinct from the plan generating a release between two heterorganic consonants, denoted as /b<sup>3</sup>d/, acoustically [b<sup>3</sup>d]. Recall now that, in fast speech, the schwa in heterorganic [b<sup>3</sup>d] sequences is not present. In Heath's

terms, the schwa in [b<sup>ə</sup>d] is ‘deleted’ by the application of an optional syncope rule. In our terms, fast speech changes the kinematics of gestures so that their targets are achieved faster, with the demonstrated effect of eliminating the release in heterorganic sequences. The crucial fact is that when the final two consonants are identical, as in [t<sup>ə</sup>t], the optional syncope rule which would otherwise ‘delete’ the schwa is inapplicable: “Optional Forward Syncope . . . cannot convert /ZnaTəT/ into \*/ZnaTT/” (H, p. 232).

This phenomenon, described above as an exception to the rule of Forward Syncope, is in fact a prediction of our analysis. Schematically, the two different coordination plans for /b<sub>o</sub>d/ and /t<sub>o</sub>t/ are illustrated in (11a) and (11b) below, shown at a fast rate. The vertical lines cutting across gestural curves depict the coordination relations. The mnemonics are, as usual, ‘o’ for onset, ‘t’ for target, ‘cc’ for c-center, ‘r’ for release, and ‘roff’ for release offset.

- (11) Two different coordination relations, (a) /b<sub>o</sub>d/ and (b) /t<sub>o</sub>t/, at a fast rate of speech

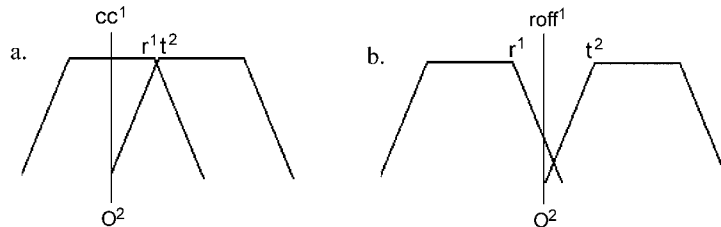

The coordination plan in (11a) is /b<sub>o</sub>d/, with the two gestures coordinated as dictated by CC-COORD. This is the *same* coordination plan as that of (7), but here the gestures are executed at a higher speed. As discussed earlier, increasing speed changes gestural kinematics so that the release of the first gesture  $r^1$  occurs at approximately the same time as the achievement of target of the second gesture  $t^2$ . The acoustic release is effectively eliminated. Qualitatively, (11a) is precisely what was observed in the simulations of rate effects on the schwa in /b<sub>o</sub>d/ sequences using GEST, described in the previous section. Figure (11b) depicts the coordination relation /t<sub>o</sub>t/. Crucially, the onset of the second /t/ gesture begins at a point late in the release phase of the first /t/ gesture, its release offset. This plan, then, guarantees that independent of the speed of gestural execution, the onset of the second /t/ gesture begins at the release offset of the first, a point in time when the vocal tract is open. This is why at fast rates ‘Forward Syncope is blocked’ in [t<sup>ə</sup>t] sequences, but not in heterorganic sequences.<sup>3</sup>

<sup>3</sup> Heath sometimes transcribes [ZnaTəT] as [ZnaT^T], writing “in any event, with separate articulation of the stops” (H, p. 232). This provides further support for our assumption

Up to now, we have considered identical oral gestures that belong to identical segments, as in [t<sup>3</sup>t], [s<sup>3</sup>s]. Consider now identical oral gestures which belong to different segments. For example, the tip-blade or TT gestures of the coronal stops /t, d, T, D/ are identical, with CL = [alveolar] and CD = [closure]. But /t/ and /d/ differ in that the glottal gesture for /t/ has CD = [wide] (glottal abduction), whereas that of /d/ has the degree appropriate for voicing, which is assumed to be CD = [critical]. The segments /t/ and /T/ differ in that the latter has, in addition to the gestures of /t/, a tongue-root or TR gesture with CL = [pharyngeal] and CD = [narrow].

In underived stems, Heath writes that “nonidentical sequences of Cs from the set /t d T D/ separated just by a schwa at the end of the stem do not happen to occur” (H, p. 249). Since there are no /tVd/-final stems, there are also no examples in active word-formation of /t d/ that would be required to form a cluster in some template. However, evidence bearing on the issue at hand is found at the stem-(inflectional) suffix boundary. The relevant examples involve the perfective suffix /-ət/, denoting third person feminine singular. When this suffix attaches to a verbal stem that ends in a VC, its schwa deletes unless the C of the stem is one of /t, d, T, D/: “when the stem-final C is from the set /t, d, T, D/, the schwa (or at least a hiatus) is retained: /mat-ət/ ‘she died’, /naD-ət/ ‘she got up’, etc. This is not the case with other alveolars /s S l r R n/, as shown above in /bas-t/, and also in /kan-t/ ‘she was’, /gal-t/ ‘she said’, /dar-t/ ‘she did’, etc.” (H, p. 233). The last four consonants of the set /s S l r R n/ are sonorants. Their overlap with obstruents is discussed in the next section. The first two consonants /s S/ are fricatives and apparently they do not show avoidance of overlap when combined with the stop /t/. The same applies to the fricative /š/, with a [postalveolar] [critical] TT gesture, when in combination with the /t/, /šot/. Recall that in a form like [ZnaT<sup>3</sup>T] or [ZnaT<sup>~</sup>T] the release is obligatory, but the plural of /fRšiT-a/ ‘fork’, [fRaš<sup>3</sup>T] shows the variant without the release [fRaš<sup>~</sup>T] (H, pp. 232, 247). Hence, clusters of consonants from the set /t, d, T, D/ show avoidance of overlap, but apparently clusters of a coronal fricative plus coronal stop do not show any such avoidance.

---

that the transitional schwa is not a vowel, but rather a release between two consonantal constrictions, for the following two reasons. First, true schwa vowels in lexical items like /DəHk/ ‘laughter’, /kəbš/ ‘ram’, /dhəb/ ‘gold’, and /sqəf/ ‘roof’ are never written in that way. Second, suppose that the schwa in [ZnaT<sup>3</sup>T] was an actual vowel. In Heath’s terms, the schwa between two final consonants is vulnerable to the optional rule of ‘Forward Syncope’, except when that vowel is found between two identical consonants. But then it would be precisely in this latter context where one would expect that ‘vowel’ to be transcribed *consistently* as a schwa and not as a release, ‘~’. Instead, we find that the schwa is sometimes transcribed (by Heath) with a release in the environment where it is not vulnerable to syncope, that is, between two identical consonants.

We may now return to the statement of the OCP, “Overlapping identical oral gestures are prohibited”, to justify the qualifications ‘identical’ and ‘oral’. First, I define the notion of gestural identity. We say that two gestures  $g^1, g^2$  are identical,  $g^1 = g^2$ , iff they employ the same *articulator* and the same values for the *constriction degree* (CD) and *constriction location* (CL) tract variables. Hence, the TT gestures of /t/ and /d/ are identical, but those of /t/ and /s/ are not since the TT gesture of /t/ has CD = [closure] and that of /s/ has CD = [critical]; the velic gestures of /n/, /m/ are identical, and so on. In MCA, gestural identity is crucial in the statement of the OCP. As seen, /toD/ violates the OCP but /soT/ does not; /t/ and /D/ have identical TT gestures but /s/ and /t/ do not.

Consider also the qualification ‘oral’ in the statement of the OCP. Among the three types of gestures, oral, laryngeal and velic, it is only identical oral gestures that show OCP effects in MCA. For consonants with identical laryngeal gestures, as in the two final consonants of [bwib<sup>o</sup>D] ‘white (diminutive)’, [Sif<sup>o</sup>T] ‘to send’, the release is optional. Similarly, consonants with identical velic gestures like /m/, /n/ do not show OCP effects. The adjective /smin/ ‘fat’ has diminutive [smim<sup>o</sup>n]. If overlapped velic gestures triggered a violation of the OCP, then, as will be seen in the next section, the expected outcome would be \*[smiy<sup>o</sup>n]. The appropriate statement of the OCP is given in (12).

- (12) OCP: “Overlapping segments with identical oral gestures are prohibited”  
 Let  $S^1, S^2$  be two segments and  $g^1, g^2$  be two oral gestures of  $S^1, S^2$  respectively. The sequence  $/S^1 \circ S^2/$  is prohibited iff  $g^1 = g^2$ .

We are now also in a position to justify the role of oral gestures in the statement of CC-COORD. We have assumed that inter-segmental coordination constraints coordinate the head or oral gestures of two segments. Within a segment, non-head gestures are in turn coordinated with the head gesture in the characteristic way particular to that segment. Recall that in MCA a sequence /b, d/ is coordinated by CC-COORD as in (13a) (laryngeal gestures not shown). In (13b), we see the same coordination relation for /n, n/. Each /n/ consists of a pair of an oral and a velic gesture. The oral gesture is a TT gesture, and ‘VEL’ stands for Velic. Since the two /n/’s have identical oral gestures, the relation in (13b) would incur an OCP violation. Indeed, (13b) is avoided. The attested relation for /n, n/ is (13c). Crucially, each oral, nasal pair of gestures in (13c) maintains its segment-internal temporal coherence. For example, we do not find (13d) or variants thereof. In (13d), the oral gestures of the two nasals shift further apart to avoid viol-

ating the OCP, but the two velic gestures do not shift along with their oral gestures. Instead, the velic gestures are coordinated independently from the oral gestures, as would be the case if CC-COORD acted ‘within tiers’ by coordinating each oral, velic, laryngeal gesture of a segment with the corresponding oral, velic, laryngeal gesture of the following segment. This is a plausible coordination scheme since, as discussed before (12), two overlapped velic gestures do not violate the OCP. However, the predictions of this scheme do not agree with the data. Orchestrating the gestures as in (13d) would result in nasalization of the transition between the two oral gestures, and a lag between the oral and velic gestures of the second /n/. Clearly, this is not how a final sequence of /n, n/ sounds.

- (13) Attested, (a, c), and unattested, (b, d), inter-segmental coordination patterns in MCA

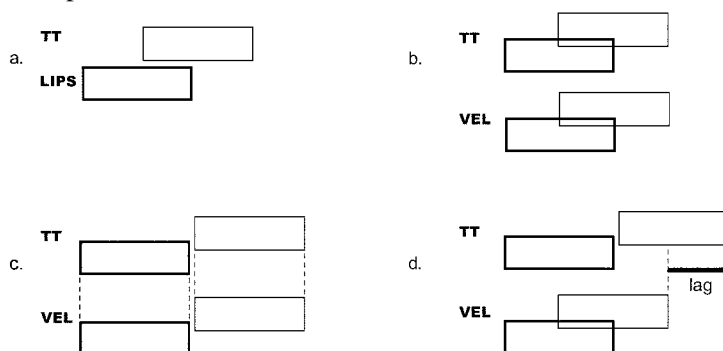

Percepts: (a) [b<sup>o</sup>d] (b) [nn] (c) [n<sup>o</sup>n] (d) [n<sup>o</sup>nt]

Thus, when the oral gestures of two segments shift apart under the pressure of the OCP, as in (13c), their associated velic gestures move along accordingly, maintaining their individual temporal relations with the oral gestures. In other words, *inter-segmental* coordination is driven by the oral gestures of the segments involved. This proposal finds some important precedents in the literature on *intra-segmental* organization. In feature geometry, the oral node may be designated as the ‘primary articulation’ under the Root node (Sagey 1986; Halle 1995). Closer to our view is Kingston’s (1985) work on the coordination of oral and laryngeal gestures. Kingston introduces a notion of ‘articulatory binding’ to express the fact that contrastive laryngeal articulations tend to be bound to the release of oral stops. Also, Steriade (1993, 1994) directly encodes ‘anchor’ positions of oral closure and release to explain facts about possible segments with contrastive laryngeal and velic articulations. In the context of this paper, the novel point is that oral gestures also drive segment-to-segment coordination.

With the two constraints OCP and CC-COORD defined, I also give the version of tableau (10) for heterorganic consonants, as in the active participles [kat<sup>ə</sup>b], [taq<sup>ə</sup>b] derived from /ktəb/ ‘write’, /tqüb/ ‘puncture’ respectively. In a sequence of heterorganic consonants, the OCP is irrelevant. We expect the emergence of the default coordination relation, as dictated by CC-COORD. The tableau is in (14) below. Candidate (14a) /t<sup>ə</sup>b/ employs the non-overlapped coordination relation, where the onset of /b/ is synchronous with the release offset of /t/. This would result in an acoustic release, as in [t<sup>ə</sup>b], which persists even in fast speech. Candidate (14b) coordinates the two consonants with the default coordination relation, /təb/. This relation also results in an acoustic release, [t<sup>ə</sup>b], but crucially this release is eliminated in fast speech. This is fully consistent with the reported behavior of such sequences.

- (14) CVC with heterorganic profile mapped to a CC cluster: Emergence of default coordination

Base: /tVb/	OCP	CC-COORD
a. /t <sup>ə</sup> b/ [t <sup>ə</sup> b]		*
b.  /təb/ [t <sup>ə</sup> b]		

To sum up, as a consequence of the ranking OCP  $\gg$  CC-COORD, the structural analysis induced on a sequence of two consonants with identical oral gestures when mapped to a template-final cluster has the surface effect of a stable release, as in [t<sup>ə</sup>t]. The underlying gestural relation is /t<sup>ə</sup>t/. In /t<sup>ə</sup>t/, the two consonants drift further apart than in /təb/ so as to avoid violation of the OCP. Thus, coordination relations can be altered under pressure from higher ranked constraints. Equivalently, templates are elastic or can be (locally) stretched in time to accommodate ambient segmental sequences, here /t<sup>ə</sup>t/, not /tət/. For sequences of heterorganic consonants, the OCP is not at stake. This allows for the emergence of the default coordination relation, the one dictated by CC-COORD, as in /təb/.

4.1.2.2. *Sequences with Different Sonority.* We now consider sequences of consonants which differ in sonority and have identical or similar oral gestures, e.g., /dn, Sl, Dl, rt, Dl, nt, tl/. These consonants combine in final CC sequences as shown by the following representative examples: /fddan/ ‘field’ [fdad<sup>ə</sup>n], /TbaSil/ ‘plate’ [TbaS<sup>ə</sup>l], /sarut/ ‘key’ [swar<sup>ə</sup>t], /SanDal/ ‘sandals’, [SnaD<sup>ə</sup>l], /Hanut/ ‘shop (fem.)’ [Hwan<sup>ə</sup>t] (all plurals, H, pp. 103, 114–115). However, unlike [ZnaT<sup>ə</sup>T] ‘tails’ with an obligatory release even in fast speech, there is no persistence of the releases in the final clusters of words like [fdad<sup>ə</sup>n] and [SnaD<sup>ə</sup>l]. This suggests that

consonants with identical oral gestures but with different sonority do not show avoidance to overlap, or at least do not show avoidance to overlap as strongly as consonant sequences with identical oral gestures and equal sonority. This appears to be consistent with Heath's specific comments on avoidance of overlap for homorganic nasal-stop sequences: "Homorganic nasal-stop clusters follow suit but more weakly" (H, p. 232) than clusters of identical consonants examined above. One example that may speak to this issue comes from the behavior of loans such /munaD-a/ 'soft drink' with Plural [mwan<sup>3</sup>D] (H, p. 106). Here, /n/, /D/ avoid bonding in the derived form. However, a year later the same informant gave Plural [mwand], with no release. There are a few more relevant examples that may be mentioned in this context but overall there is insufficient evidence to determine the correct analytical choice here.

In particular, there are two analytical choices that may be pursued. First, as suggested to me by Ignatius Mattingly, the weakening effect for clusters of different sonority could be only apparent. The release of a nasal is not audible or at least is less audible than the release of an oral stop. In a nasal, there is uninterrupted airflow through the nasal cavities. This reduces the supraglottal pressure behind the oral constriction, and thus the audibility of the oral release. The same holds for the lateral /l/, with airflow escaping through the lateral channel. If this is the correct interpretation, the coordination pattern underlying both acoustic outputs [n<sup>3</sup>d] ~ [nd] would be in violation of CC-COORD, driven by the OCP.

Alternatively, assume that avoidance of overlap truly weakens as the CC profile changes from equal to unequal sonority. This is consistent with work on OCP effects which does indeed suggest that a more refined notion of 'identity' is involved (Padgett 1992; Pierrehumbert 1993; Selkirk 1993; Berkley 1994). In a sequence of segments, identity of their oral gestures would be a necessary but not a sufficient condition for violating the OCP. The sonority of the segments these oral gestures are part of would also be relevant. Hence /T<sup>3</sup>od/ would violate the OCP, but /l<sup>3</sup>od/ would not. Though the two oral gestures are identical, they belong to segments of different sonority. The correct statement of the OCP would then be: "Let  $S^1$ ,  $S^2$  be two segments and  $g^1$ ,  $g^2$  be two oral gestures of  $S^1$ ,  $S^2$  respectively. The sequence  $/S^1 \circ S^2/$  is prohibited iff  $\text{Sonority}(S^1) = \text{Sonority}(S^2) \wedge g^1 = g^2$ ." As Browman and Goldstein (1989) have shown, the classification of a segment as [ $\pm$ sonorant] can be determined as the combined aerodynamic effect of the set of gestures that are part of that segment. However, I will not expand on this point. The reader is referred to Browman and Goldstein's (1989, pp. 235–242) and also Bird's (1995, pp. 124 ff.) discussion of characterizing the major class feature [ $\pm$ sonorant] in a gestural model.

I will leave the issue of avoidance of overlap between consonants with different sonority for further research.<sup>4</sup> The core argument of this paper does not rest on the precise behavior of homorganic consonants with different sonority with respect to overlap. What is important to the argument is the distinction between sequences of heterorganic consonants and sequences of consonants with identical oral gestures which belong to segments of equal sonority. For both of these the facts are indisputable. The former show no avoidance of overlap, but the latter systematically avoid overlap in ways discussed in the previous section, and others to be discussed in forthcoming sections.

#### 4.1.3. *Summary*

The analysis above illustrates a fundamental point. Different input CVC sequences, with the two Cs heterorganic or identical, map to the same acoustic output, [C<sup>o</sup>C]: /ktəb/ ‘write’ → [kat<sup>o</sup>b] and /ZnTiT/ ‘tail’ → [ZnaT<sup>o</sup>T]. Crucially, however, the structural analyses assigned to these outputs by the grammar are distinct. Sequences of the [t<sup>o</sup>b] type employ a different coordination relation from that of the [t<sup>o</sup>t] type. The former satisfy CC-COORD, the latter violate it. Equivalently, our grammar induces a *harmonic ordering* (Prince and Smolensky 1993) of the two structural analyses so that the *temporal harmony* of [t<sup>o</sup>b] is higher than (>) that of [t<sup>o</sup>t]. Precisely this ‘low-level’ coordination difference will be shown in detail below to have ‘higher-order’ or more salient consequences in the phonology of the language.

#### 4.2. *Template Satisfaction*

In this section, I argue that certain ‘higher-order’ phonological properties of templates also derive from a coordination-sensitive grammar. To preview, the default strategy for filling the C<sup>3</sup> position of the adjectival diminutive /CCiCC/ template is to duplicate C<sup>2</sup> of the base, ‘fat’ /smin/ → [smim<sup>o</sup>n]. Deviation from this default is seen in a class of diminutives where a glide serves as the filler consonant, ‘thin’ /rqi/ → [rqi<sup>o</sup>q]. The otherwise canonical \*[rqi<sup>o</sup>q] is avoided because of the relatively low temporal harmony of [q<sup>o</sup>q]. In fact, not only these exceptions but also the default fill-in strategy is shown to derive from temporal coordination as opposed to, say, edge-in association of consonants to templates. Hence, a coordination-sensitive grammar determines the fill-in strategy

<sup>4</sup> See also Dell and Elmedlaoui (1996, especially pp. 362–363, 370) for sonority’s complicating role in the distribution of releases in Imdlawn Tashlhiyt Berber consonant transitions.

for a template, the means of Template Satisfaction (McCarthy and Prince 1995a).

I begin with adjectival diminutives, which employ the template /C<sup>w</sup>CiCC/. The data shown in (15) are drawn from H (p. 153). The secondary labialization, which appears to be a property of this and other MCA templates, can be safely ignored here (see H, pp. 354 ff.). The canonical means of filling C<sup>3</sup> of the output template is by repetition of the medial base consonant, (15a). There are only a few true exceptions to this pattern, shown in (15c) (see H, p. 265, for a possible explanation of their exceptionality involving sonority sequencing constraints). The other ‘exceptional’ forms in (15b) are adjectives of the shape CC<sub>x</sub>iC<sub>x</sub>, but their exceptionality is systematic. As Heath notes, these adjectives do not form output \*CC<sub>x</sub>iC<sub>x</sub><sup>o</sup>C<sub>x</sub> (H, pp. 157, 232). Rather, glide epenthesis is used to fill the C<sup>3</sup> of the template, as in ‘new’ /ždid/ → [ždiy<sup>o</sup>d].

(15)	Gloss	Adjective	Diminutive
a.	‘hot’	sxun	→ s <sup>w</sup> xix <sup>o</sup> n
	‘big’	kbir	→ k <sup>w</sup> bib <sup>o</sup> r
	‘crazy’	Hməq	→ Hmim <sup>o</sup> q
	‘fat’	smin	→ smim <sup>o</sup> n
	‘cross-eyed’	Hwəl	→ Hwiw <sup>o</sup> l
b.	‘few’	qlil	→ q <sup>w</sup> liw <sup>o</sup> l, q <sup>w</sup> liy <sup>o</sup> l
	‘new’	ždid	→ ždiy <sup>o</sup> d
	‘thin’	rqi	→ rqi <sup>o</sup> q
c.	‘small’	SGiR	→ S <sup>w</sup> Giw <sup>o</sup> R
	‘short’	qSiR	→ q <sup>w</sup> Siw <sup>o</sup> R
	‘many, much’	ktir	→ k <sup>w</sup> tiy <sup>o</sup> r

Consider first the diminutive for a canonical base consisting of three non-identical consonants, as in /Hməq/ ‘crazy’ → [Hmim<sup>o</sup>q]. The diminutive must conform to the shape /CCiCC/.<sup>5</sup> Let us encode this requirement with a constraint, TEMPLATE. Since /Hməq/ has only three consonants, action must be taken to ensure that each template position is occupied by some consonant. In this case, the medial consonant of the base is repeated in the derived word. The resulting dissimilarity between base and derived word

<sup>5</sup> I simplify the statement of the template by expressing it as a sequence of C’s and V’s. In an alternative formulation of templatic constraints, one could employ purely prosodic predicates, in accordance with McCarthy and Prince’s (1995a) ‘prosodic morphology’ hypothesis. The precise formulation of templatic constraints is not crucial for present purposes.

violates one of the basic faithfulness constraints of Correspondence Theory called INTEGRITY, defined below (from McCarthy and Prince 1995b). The single /m/ in /Hməq/ corresponds to two segments in the derived form [Hmim<sup>ə</sup>q]. INTEGRITY penalizes such double correspondence, indicated here with coindexation of the correspondent segments. INTEGRITY is violated in /Hməq/ → [Hmim<sup>ə</sup>q] because of the requirement that a diminutive must conform to the shape /CCiCC/, that is, TEMPLATE ≫ INTEGRITY.

- (16) INTEGRITY: No segment of S<sub>1</sub> has multiple correspondents in S<sub>2</sub>  
 INTEGRITY violation: H m<sub>α</sub> ə q ‘crazy’ Base (= S<sub>1</sub>)  
 H m<sub>α</sub> i m<sub>α</sub><sup>ə</sup> q ‘crazy – diminutive’ Derived (= S<sub>2</sub>)

The issue of interest here, however, is not that the template is satisfied, but rather the precise way in which it is satisfied. In particular, for /Hməq/ → [Hmim<sup>ə</sup>q], tableau (17) enumerates some alternative diminutive outputs that are to be compared to the actual output in (17a). Since focus is on the final cluster of each candidate, I indicate only the coordination relation that obtains between the two final consonants. In doing so, as usual, /C<sup>o</sup>C/ denotes the temporal relation required by CC-COORD, and /C=C/ denotes the other relation with the two consonants farther apart in time. The corresponding acoustic outputs in ‘[. . .]’ accompany these abbreviated gestural scores. In the actual output of (17a), the medial /m/ is duplicated, incurring a violation of INTEGRITY. The second instance of /m/ is coordinated with the final /q/ according to the demands of CC-COORD, /m<sup>ə</sup>q/. Compare this to form (17b) which fills the third C position by inserting a glide. Glide insertion or epenthesis incurs a violation of another basic constraint of Correspondence Theory known as DEP, “Every segment of S<sub>2</sub> (Derived) has a correspondent in S<sub>1</sub> (Base).” Since (17a) is the actual output we infer that DEP ≫ INTEGRITY. Intuitively, this ranking expresses the fact that the template /CCiCC/ must be satisfied by duplication of a base consonant, not by epenthesis.

- (17) Derivation of /Hməq/ ‘crazy’ → /Hmim<sup>ə</sup>q/, [Hmim<sup>ə</sup>q]; Inferred ranking: DEP ≫ INTEGRITY

Base: /Hməq/	OCP	CC-COORD	DEP	INTEGRITY
a.  /Hmim <sup>ə</sup> q/ [m <sup>ə</sup> q]				*
b. /Hmiy <sup>ə</sup> q/ [y <sup>ə</sup> q]			*!	
c. /Hmiq <sup>ə</sup> q/ [q <sup>ə</sup> q]		*!		*
d. /Hmiq <sup>ə</sup> q/ [qq]	*!			*

Candidate (17c), /Hmiq<sup>ə</sup>q/, [Hmiq<sup>ə</sup>q], duplicates the stem-final /q/ to create a final [C<sup>ə</sup>C] sequence. This violates INTEGRITY but also CC-COORD,

a superset of the violations incurred by the actual output (17a), /Hmim<sup>o</sup>q/, [Hmim<sup>o</sup>q]. Candidate (17d) duplicates the final /q/ and coordinates the two /q/s according to CC-COORD. It therefore incurs a violation of INTEGRITY, as in the actual output, but also a violation of the OCP. The constraints OCP and CC-COORD are not yet ranked with respect to DEP, INTEGRITY.<sup>6</sup>

A crucial point in the above analysis is the harmonic relation between /Hmim<sup>o</sup>q/ > \*/Hmiq<sup>o</sup>=q/. This relation is established on the basis of a coordination-sensitive grammar. The form /Hmim<sup>o</sup>q/ satisfies the coordination constraint CC-COORD, but /Hmiq<sup>o</sup>=q/ violates it. A coordination-sensitive grammar then derives the choice of the copied consonant, and the fact that final consonants do not duplicate. The question is whether the role of coordination in the grammar is crucial. To answer it, we will first observe that there is a class of a-temporal grammars that *can* derive the choice of the copied consonant. Then, we will see that this is only true for a limited set of data. When all the facts are considered, the a-temporal grammars make the wrong predictions, unlike the coordination-sensitive grammar which makes the right predictions.

Consider an analysis within an a-temporal theory of grammar. The standard view of word-formation in templatic morphology is that words are formed by mapping consonants and sometimes vowels to template positions. The medial duplication in /Hm<sup>o</sup>q/ ‘crazy’ → [Hmim<sup>o</sup>q] is reminiscent of the *edge-in* mode of association of consonants to templates (Yip 1988, Buckley 1990, Hoberman 1992). According to this mode, seen in (18) below, the two consonants at the edges of the stem undergoing morphological derivation are first associated to the corresponding edge positions in the template. In a second step, the unassociated /m/ would be linked to the unassociated template slots.

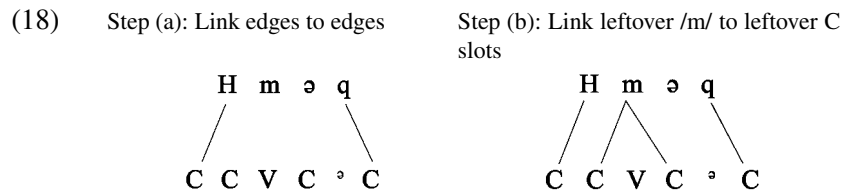

Edge-in association was originally proposed within a derivational conception of grammar but the idea is not inherently derivational. We can derive

<sup>6</sup> The acoustic output corresponding to /q<sup>o</sup>q/ in (17d) is [qq]. Thus, form (17d) may be acoustically indistinguishable from a candidate which fills the final CC cluster by gemination, /Hmiqq/, [qq]. As will be seen in the next section, gemination is not used to fill CC clusters in MCA, except in instances where it is a morphological requirement of the specific template.

the same effect using parallel evaluation of candidates by constraints capitalizing on the distinction between final (edge) and medial consonants. The constraints I am referring to are faithfulness constraints sensitive to the position of segments. For example, building on McCarthy and Prince's (1995b) Correspondence Theory, one may assume a species of the so-called Anchoring constraints that are satisfied when a segment's position as constituent-initial or -final is preserved under correspondence (e.g., see Ussishkin 1999). By appropriately stating that preserving the position of edge segments is more important than preserving the position of non-edge segments, one may effectively ban duplication of edge consonants.

Derivational or constraint-based a-temporal models, then, can derive edge-in association or medial duplication. However, the role of temporal coordination in the grammar of MCA is crucial. A-temporal, coordination insensitive grammars cannot derive the following fact. The diminutive of stems like /rqi/ 'thin' is [rqi<sup>3</sup>q]. That is, CC<sub>x</sub>iC<sub>x</sub> adjectives never give diminutive \*CC<sub>x</sub>iC<sub>x</sub><sup>3</sup>C<sub>x</sub>, even though repetition of a consonant is the canonical way to fill the template, as seen above (H, pp. 157, 232). Heath's proposal for the ill-formedness of \*CC<sub>x</sub>iC<sub>x</sub><sup>(3)</sup>C<sub>x</sub> is that "this would threaten to create a secondary geminate at the end of the stem" (H, p. 157), and that "in general, separate identical Cs tend strongly to avoid secondary gemination in a variety of ways" (H, p. 232).<sup>7</sup> 'Secondary gemination', in this context, refers to a sequence of two separate, identical consonants brought into contiguity, as a result of mapping consonants to templates. The following analysis essentially expresses Heath's intuition formally. Specifically, any account of the sub-optimality of \*CC<sub>x</sub>iC<sub>x</sub><sup>(3)</sup>C<sub>x</sub> must exclude at least two different candidates: (a) /C<sub>x</sub>oC<sub>x</sub>/, [C<sub>x</sub>C<sub>x</sub>], where the final cluster is filled with two separate, identical consonants coordinated as in CC-COORD, and (b) /C<sub>x</sub>≡C<sub>x</sub>/, [C<sub>x</sub><sup>3</sup>C<sub>x</sub>], where the final cluster has been filled with two separate, identical consonants coordinated with the non-overlapped relation.

Tableau (19) enumerates the relevant candidates for /rqi/ 'thin' → [rqi<sup>3</sup>q]. The actual output is (19a) /rqi<sup>o</sup>q/, [y<sup>3</sup>q]. In this form, the template's C<sup>3</sup> is not filled by consonant doubling but rather by glide epenthesis, hence the violation of DEP. Candidate (19b) /rqi<sup>1</sup>iq<sup>1</sup>≡q<sup>2</sup>/, [q<sup>3</sup>q] brings out the crucial point. This candidate does fill the template by duplicating the medial consonant /q<sup>1</sup>/, yet it is not the actual output. A [q<sup>3</sup>q] sequence violates the preferred coordination relation in CC clusters, the requirement of the constraint CC-COORD. This is because, as discussed earlier, the

<sup>7</sup> McCarthy (1986) identifies a range of similar phenomena, which he calls 'antigemination', in various languages. As argued, in MCA, we must treat 'anti-gemination' in temporal, not spatial terms (there is no vowel epenthesis).

coordination required for an acoustic release in a sequence of two identical consonants is different from that required by CC-COORD.

- (19) Derivation of /rqi/ ‘thin’ → /rqiyoq/, [rqiyoq]; Inferred ranking: CC-COORD ≫ DEP

Base: /rqi/	OCP	CC-COORD	DEP	INTEGRITY
a.  /rqiyoq/ [yyoq]			*	
b. /rq <sup>1</sup> iq <sup>1</sup> ⇒q <sup>2</sup> / [qyoq]		*!		*
c. /rq <sup>1</sup> iq <sup>1</sup> oq <sup>2</sup> / [qq]	*!			*

We may thus infer an additional ranking relation, CC-COORD ≫ DEP. Intuitively, the ranking CC-COORD ≫ DEP expresses the fact that temporal coordination drives template satisfaction in MCA. That is, when proper temporal coordination is at stake, template satisfaction resorts to glide epenthesis (compare candidates 19a, b). The other two ranking relations shown in the tableau were inferred earlier. Consider also candidate (19c). Its two final, identical consonants are related as required by CC-COORD. This is a violation of the OCP. It is clear that other candidates like \*/rq<sup>1</sup>iq<sup>2</sup>⇒q<sup>2</sup>/, [qyoq] or \*/rq<sup>1</sup>iq<sup>2</sup>oq<sup>2</sup>/, [qq] are sub-optimal for the same reasons as candidates (19b) and (19c) respectively; the former violates CC-COORD, the latter violates the OCP.

Before leaving the diminutive, consider yet another possible account for the sub-optimality of \*[rqiyoq]. The grammar could include a constraint against triple association, that is, one /q/ linked to three template positions. Prunet and Petros (1996) propose such a constraint on the basis of data from the frequentatives of Western Gurage languages. In MCA, this constraint is not relevant. Two identical consonants in underived stems like /rqi/ ‘thin’ are separate and independent, and do not derive from long-distance spreading. There are numerous arguments supporting this claim in MCA. Heath (1987) argues forcefully for it at various points (representative arguments can be found in pp. 7, 144–145, 188–189, 222, 339). This agrees with the independent proposals in Gafos (1996, 1998) for eliminating long-distance consonant spreading in general (see also Kenstowicz and Banksira 1999; Rose 2000).

Coordination effects in word-formation are by no means limited to the adjectival diminutive. Glide epenthesis is observed in other templates where the conditions for generating a potential CC cluster of two identical consonants are met. For instance, consider the professional noun template /CCaCC-i/ (H, pp. 140–141). When the base contains a medial geminate, the derived professional noun appears with two single instances of the base consonant: /s<sup>w</sup>kkaR/ ‘sugar’, [skakR-i] ‘dealer in sugar’, /Sbbən/

‘wash clothes’, [Sb<sup>abn</sup>-i] ‘washer’. However, when the base contains a medial geminate followed by an identical third consonant as in /Hm<sup>mam</sup>/ ‘public bath’, the derived word shows a glide in the third C position of the template, [Hm<sup>aym</sup>-i] ‘owner of public bath’. The otherwise expected \*[Hm<sup>mam</sup><sup>(ə)</sup>-i] is avoided because, as shown earlier, either the OCP or CC-COORD would be violated.

I now turn to some cases where coordination effects in word-formation are apparently not observed. Recall that the adjectival diminutive admits bases that have at most three consonants and requires the template /CCiCC/. Other morphological categories permit a wider range of base forms and in some of these, it turns out, one finds derived [t<sup>ə</sup>t] sequences, with the sub-optimal temporal relation that is visibly avoided in the adjectival diminutive and elsewhere. One such morphological category is nominal plurals, with representative examples shown below (H, pp. 103, 105, 231–232).

(20) Nominal plural; template is /CCaCC/

nimiru ‘number’	→ [nwam <sup>ə</sup> r]	blaS-a ‘place’	→ [blay <sup>ə</sup> S]
ZnTiT ‘tail’	→ [ZnaT <sup>ə</sup> T]	wlsis ‘swollen gland’ <sup>8</sup>	→ [wlas <sup>ə</sup> s]

The examples for ‘tail’ and ‘swollen gland’ illustrate what Heath refers to as ‘aversion to bonding’: “these are cases where two identical Cs that should be brought together in a cluster by ordinary phonological rules ... retain separate articulation and releases” (H, p. 231). However, unlike aversion to bonding in adjectival diminutives, /ždid/ ‘new’ → [ždiy<sup>ə</sup>d], not \*[ždid<sup>ə</sup>d] or \*[ždidd], glide anaptyxis is not an option in the nominal plural. The plural of /ZnTiT/ ‘tail’ is [ZnaT<sup>ə</sup>T], not \*[Znay<sup>ə</sup>T]. Moreover, both the nominal plural and the adjectival diminutive templates consist of four C positions, /CCaCC/ and /CCiCC/, respectively. Whence this difference? An independent and well-established fact about templatic morphology is the requirement that all consonants in the base must appear in the derived form (McCarthy 1979, Yip 1988). This is part of what is involved in deriving the difference between /ždid/ ‘new’ → [ždiy<sup>ə</sup>d] and /ZnTiT/ ‘tail’ → [ZnaT<sup>ə</sup>T]. The form /ždid/ has three consonants, but /ZnTiT/ has four. When /ždid/ is mapped to the /CCiCC/ template, the two base /d/s can both be parsed in the derived word without being forced into contiguity in the final CC cluster, hence [ždiy<sup>ə</sup>d]. Since the template has four C positions and the base has only three consonants, glide anaptyxis can apply here to avoid the marked coordination of \*[ždid<sup>ə</sup>d] (see (19)). But when the base

<sup>8</sup> Heath’s gloss for /wlsis/ is ‘ulcer, abscess’. Thanks to Mohamed Guerssel for the correction.

is /ZnTiT/, four consonants must surface in a template with just four consonant positions. Glide anaptyxis is not an option here, because it would imply leaving one of the consonants out of the derived form.

To express these observations formally, we only need to add to our grammar the parsing requirement, MAX-C, “Every consonant in the base must surface in the derived form” (McCarthy and Prince 1995b). The relevant candidates for the plural of /ZnTiT/ are shown in tableau (21). The actual output is (21a). The two /T/’s of the base must appear in the derived word, due to the dominating MAX-C constraint. Their timing is determined by the ranking OCP  $\gg$  CC-COORD. In effect, the two consonants are pushed further apart, locally stretching the template in violation of the canonical temporal relation required by CC-COORD. This has the surface result of a stable acoustic release between the two identical consonants. Maintaining proper coordination as in (21b) violates the OCP. If, as in (21c), glide epenthesis is used instead to fill the template’s third C slot, then one of the base consonants must be deleted. This is a violation of the undominated MAX-C requirement. Using duplication of a base consonant, as in (21d), suffers from the same problem. Comparing candidates (21a) and (21c), we infer an additional ranking relation MAX-C  $\gg$  CC-COORD. Intuitively, the requirement that every consonant in the base must be part of the derived form takes priority over proper temporal coordination; the actual output /ZnaT<sup>1</sup> $\Rightarrow$ T<sup>2</sup>/, [ZnaT<sup>o</sup>T] employs the sub-optimal coordination relation ‘ $\Rightarrow$ ’.

- (21) Local stretching, template-finally; /ZnT<sup>1</sup>iT<sup>2</sup>/ ‘tail’  $\rightarrow$   
/ZnaT<sup>1</sup> $\Rightarrow$ T<sup>2</sup>/, [ZnaT<sup>o</sup>T]; Inferred ranking: MAX-C  $\gg$   
CC-COORD

Base: /ZnT <sup>1</sup> iT <sup>2</sup> /	MAX-C	OCP	CC-COORD	DEP	INTEGRITY
a.  /ZnaT <sup>1</sup> $\Rightarrow$ T <sup>2</sup> / [T <sup>o</sup> T]			*		
b. /ZnaT <sup>1</sup> oT <sup>2</sup> / [TT]		*!			
c. /Znay <sup>o</sup> T/ [y <sup>o</sup> T]	*!			*	
d. /Znan $\Rightarrow$ T/ [n <sup>o</sup> T]	*!				*

This concludes the argument of this section. Temporal coordination plays a crucial role in determining ‘higher-order’ properties of MCA. The argument for this claim has two parts. In the first part, it was shown that the choice of the copied consonant, medial or final, or the means of template satisfaction, duplication or epenthesis, are lawful consequences of two types of constraints: markedness constraints referring to the spatio-temporal dimension of phonological form (CC-COORD, OCP), and generally accepted faithfulness constraints evaluating the similarity between related forms (MAX, DEP, INTEGRITY). The second part of the argument

examined alternative accounts of the relevant MCA properties, involving mechanisms of a-temporal phonology such as directional or parametric principles of association to templates and variants thereof. These mechanisms cannot account for the data.

#### 4.3. *Geminate (in-)separability*

I now turn to another generalization concerning the behavior of geminates mapped to templates with a final CC cluster: “Schwa Insertion in a CC cluster following a full ablaut V is prohibited when the corresponding input Cs form a geminate  $C_x C_x$ ” (H, p. 106). For example, the reciprocal requires a final CC sequence as in /ngür/ ‘pester’ → [t-nag<sup>ə</sup>r], but the reciprocal of /šəmm/ ‘smell’ is [t-šamm], not \*[t-šam<sup>ə</sup>m]. Geminates are well-known for their resistance to splitting, a property known as geminate integrity or in-separability (Kenstowicz and Pyle 1973; Guerssel 1977, 1978; Steriade 1982; Hayes 1986; Schein and Steriade 1986). However, the behavior of geminates in templatic word-formation has been much less studied. Specifically, in MCA templates, geminate integrity turns out to be a non-trivial issue, because geminates are separable, as in the nominal diminutive of /müxx/ ‘brain’ → [m<sup>w</sup>xiy<sup>ə</sup>x] or the professional noun of /s<sup>w</sup>kkaR/ ‘sugar’ → [skakR-i] ‘dealer in sugar’.

In this section, I argue that geminate (in-)separability in MCA is another consequence of a coordination-sensitive grammar. In the next section, I argue that a-temporal approaches to geminate (in-)separability cannot account for the facts in MCA. To preview, the reason why geminates / $C_x C_x$ / fail to split into final [ $C_x^ə C_x$ ] sequences is precisely the same as the reason why single consonants / $C_x$ / do not duplicate to final [ $C_x^ə C_x$ ] sequences, discussed in the preceding section. In both cases, a final [ $C_x^ə C_x$ ] is avoided because it requires a temporal relation that is crucially different from that of CC-COORD. In contrast, derived [ $C_x VC_x$ ] sequences, as in /s<sup>w</sup>kkaR/ → [skakR-i], with an intervening true vowel, are unproblematic with respect to coordination. The two /k/s in [skakR-i] are not directly coordinated with each other. Rather, each of the consonants is coordinated with the intervening vowel.

We begin in (22) with examples of the generalization in need of explanation here. The examples come from various morphological categories, reciprocal, active participle, nominal plural, and nominal diminutive, to emphasize the robustness of the generalization (from H, pp. 64, 92, 103, 114). For each category, I give two forms, one with a geminate-final base and another with a base that does not end in a geminate. Words derived from geminate-final bases never undergo Schwa Insertion, but words de-

rived from other bases always do. We refer to this property as *geminate in-separability*.

(22) Geminate in-separability: Final geminates do not split to  $C_x^{\circ}C_x$

Reciprocal:	šəmm ‘smell’ → t-šamm, *t-šam <sup>ə</sup> m	ngür ‘pester’ → t-nag <sup>ə</sup> r
Active participle:	Həll ‘open’ → Hall, *Hal <sup>ə</sup> l	tqüb ‘puncture’ → taq <sup>ə</sup> b
Nominal plural:	mxadd-a ‘pillow’ → mxadd, *mxad <sup>ə</sup> d	nimiru ‘number’ → nwam <sup>ə</sup> r
Nominal dimin.:	müxx ‘brain’ → m <sup>w</sup> xiy <sup>ə</sup> x, *m <sup>w</sup> xix <sup>ə</sup> x	bir ‘well (water)’ → bwiy <sup>ə</sup> r

The failure of the geminate in /šəmm/ ‘smell’ to split, \*[t-šam<sup>ə</sup>m], cannot be due to an independent prohibition on geminate splitting in templates. In MCA, geminates do split to fill templates. Representative examples are given in (23). For each example, two consonant positions in the derived word are occupied by the two ‘halves’ of the base geminate. Note that geminates split independent of their position. A final geminate splits in the passive participle /kübb/ → /m-kbub/, and a medial geminate splits in the professional noun /s<sup>w</sup>kkaR/ → /skakR-i/.<sup>9</sup> This property of geminates will be referred to as *geminate separability*.

(23) Geminate separability

Professional Noun:	s <sup>w</sup> kkaR → skakr-i	‘sugar’
Nominal Plural:	fddan → fdad <sup>ə</sup> n	‘field’
Factitive-Causative:	šəmm → šmməm	‘smell’
Passive participle:	kübb → m-kbub	‘pour’
Nominal plural:	müxx → m <sup>w</sup> xax	‘brain’ (‘ <sup>w</sup> ’ inconsistently realized)
Nominal diminutive:	müxx → m <sup>w</sup> xiy <sup>ə</sup> x	‘brain’

From (22) and (23), the generalization is that geminates do separate when an intervening vowel is present (separability), but not when the intervening element is the transitional schwa (in-separability). An initially plausible explanation for in-separability, as in /šəmm/ → [t-šamm], \*[t-šam<sup>ə</sup>m], would be to propose that the geminate in [t-šamm] satisfies the template’s structural requirement for a final CC sequence; the reciprocal template is /t-CaCC/. This seems reasonable given the often made assumption that geminates consist of two skeletal positions linked to the same

<sup>9</sup> I do not give examples of bases with initial geminates because initial geminates are extremely rare. There are a handful of particles and prepositions with initial geminates but these do not have any derivatives (H, p. 204). There is also one verb /ddi/ ‘take away’ and two nouns, /BBa/ ‘father’ and /MM<sup>(w)</sup>-/ ‘mother’. Of these, the first two do not have derivatives that exhibit geminate splitting, but ‘mother’ does in its diminutive form /mwim-t-/ (loss of pharyngealization intended), where /t/ is a feminine singular suffix (H, pp. 115, 132).

feature bundle. However, geminates are actively avoided as occupants of CC clusters in templates, *except for those cases where gemination is a grammatical requirement of the particular template*. Once the exception part of this statement is understood, the generalization stands out.

Gemination is employed in the factitive-causative, which corresponds to the Classical Arabic form II (H, pp. 71, 79). For instance, the factitive-causatives of the verbs /dxül/ ‘enter’, /šəmm/ ‘smell’, /xaf/ ‘fear’ are [dxxəl], [šmməm] and [xwwəf], respectively. The required template here is /CC<sub>x</sub>C<sub>x</sub>X/, where ‘X’ in Heath’s model stands for a template slot which can be occupied either by a consonant, as in [dxxəl], or by a vowel, as in [bkki] (from /bki/ ‘weep’). Other templates that require gemination in MCA are the mediopassive of the factitive-causative /t-CC<sub>x</sub>C<sub>x</sub>X/, corresponding to Form V in Classical Arabic (H, pp. 77, 79), the agentive of trilateral verbs /CC<sub>x</sub>C<sub>x</sub>aC/ (H, p. 134), the /CC<sub>x</sub>C<sub>x</sub>uC-i/ template in limited use to derive adjectives from verbs or other adjectives (H, p. 151), and the /CC<sub>x</sub>C<sub>x</sub>aC/ template used for only five or so active participles (H, p. 99).

With these morphologically required cases of gemination put aside, we now turn to the avoidance of filling CC clusters with geminates. This avoidance manifests itself in two ways. First, gemination is *never* used to fill extra template positions when there are more such positions than base consonants. I give representative examples from verbs, nouns, and adjectives to illustrate the robustness of the generalization. From verbs, consider the formation of reciprocals on the /t-CaCC/ template: /bus/ ‘kiss’ gives [t-baw<sup>ə</sup>s], not \*[bass], and /xaf/ ‘fear’ gives [t-xaw<sup>ə</sup>f], not \*[xaff]. From nouns, consider the nominal diminutive /CCiCC/: /müxx/ ‘brain’ gives [m<sup>w</sup>xiy<sup>ə</sup>x], not \*[m<sup>w</sup>xixx], and /bir/ ‘water well’ gives [bwiy<sup>ə</sup>r], not \*[bwirr]. From adjectives, consider the diminutives /sxun/ ‘hot’ → [s<sup>w</sup>xix<sup>ə</sup>n], not \*[s<sup>w</sup>xinn], and /ždid/ ‘new’ → [ždiy<sup>ə</sup>d], not \*[ždidd]. The same dispreference can be illustrated for initial CC clusters. In this case, however, the dispreference could be due to an independent prohibition on word-initial geminates. These are extremely rare in MCA. Since the word-initial context is not relevant to the present argument, I do not give any examples.

The second manifestation of the avoidance of geminates as CC fillers is related to the status of vowels in derivation. In general, in MCA base consonants have priority over base vowels in template mapping. This is often assumed to be a characteristic of templatic word-formation. But this effect is only the extreme case of what should be seen as preferential realization of consonants over vowels (i.e., MAX-C ≫ MAX-V). For example, the professional noun of /žurnal/ ‘newspaper’ formed on the template /CCaCC-i/ template is [žRanl-i] with all base vowels ignored. When the

base contains fewer consonants than the number of C positions in some template, then some vowels may be realized by surfacing as glides. For example, consider the plural of /sarut/ ‘key’, [swar<sup>ə</sup>t] formed on the template /CCaCC/, where the /w/ of the plural corresponds to the base /a/ vowel. Our interest here lies in the behavior of bases with final geminates mapped to templates with final CC clusters. As an example, consider the professional noun of /qamižž-a/ ‘shirt’ [qwamž-i], formed on the /CCaCC-i/ template. The base geminate shortens and combines with the preceding /m/ to give a proper CC cluster in [qwamž-i]. Moreover, the vowel /a/ of the base /qamižž-/ surfaces as the glide /w/ in [qwamž-i]. An alternative to [qwamž-i] is to leave the /a/ of /qamižž-/ unparsed, as in \*[qmažž-i]. Leaving a vowel unparsed is indeed an option as illustrated above, and in fact \*[qmažž-i] would preserve all consonantal properties of the base, including the final geminate. This form would be the expected output, then, if geminates were potential fillers of CC clusters. The fact that it is avoided illustrates the avoidance of filling CC clusters with geminates, /qamižž-a/ → [qwamž-i], not \*[qmažž-i]. The same can be illustrated with other templates such as the nominal diminutive, e.g., /müxx/ ‘brain’ → [m<sup>w</sup>xiy<sup>ə</sup>x], not \*[m<sup>w</sup>xixx].<sup>10</sup>

I thus assume that filling a CC sequence with a geminate incurs a violation of a templatic, structural constraint requiring the presence of two gestures. A geminate fails to satisfy this constraint because it is a SINGLE (long) gesture. Qualitatively, this constraint is the same as the templatic constraint called *TEMPLATE*, introduced in the preceding section. We saw, for example, that in the diminutives /sxun/ ‘hot’ → [s<sup>w</sup>xix<sup>ə</sup>n] or /rqi<sup>ə</sup>q/ ‘thin’ → [rqi<sup>ə</sup>q], the derived words have the shape-invariant /CCiCC/, where each of the consonant slots must be occupied by some consonant. Since the bases have only three consonants, either repetition of a consonant, as in /sxun/ ‘hot’ → [s<sup>w</sup>xix<sup>ə</sup>n], or glide epenthesis, as in /rqi<sup>ə</sup>q/ ‘thin’ → [rqi<sup>ə</sup>q], are employed to assign a consonant to each templatic position; hence, *TEMPLATE* ≫ *INTEGRITY*, *DEP*. Note moreover that consonant repetition, as in the diminutive of /sxun/ ‘hot’ → [s<sup>w</sup>xix<sup>ə</sup>n], and what we

<sup>10</sup> I am aware of two apparent counterexamples to the claim that geminates are disfavored as CC fillers. In the professional noun, we find /pippa/ ‘pipe’ → [ppaypp-i] and /gaRRu/ ‘cigarette’ → [gwaRR-i]. For /pippa/ → [ppaypp-i] note that [ypp] is a sequence of two distinct consonantal constrictions, where the second consonant is long. Thus, CC of the template is not filled with a geminate there. The problematic aspect of this form is with the initial gemination. H (p. 16) suggests that the actual base may be geminate-initial. Note that it is not the case that geminates are retained in the derived form in general, as can be seen by examples like /slipp/ ‘underpants’ → [slayb-i] and /drr-a/ ‘house’ → [drayr-i]. A third apparent counterexample, where a geminate seems to fill a CC cluster, is /bRquq/ ‘plums’ → [bRaqq-i]. But see section 4.6.

call geminate splitting, as in the professional noun of /s<sup>w</sup>kkaR/ ‘sugar’ → [skakR-i], are equivalent with respect to their performance on the constraint INTEGRITY. In each example, the feature bundle of one consonant has two correspondents in the derived form. INTEGRITY makes reference to the quality (the feature bundle) of segments, not to their length (see section 4.2 for the definition of the constraint).

We are now in a position to understand in a precise way why geminates /C<sub>x</sub>C<sub>x</sub>/ fail to split to final [C<sub>x</sub><sup>o</sup>C<sub>x</sub>] sequences. I illustrate with the formation of active participles. The template for the participles is /CaCC/, with a final sequence of two consonants, as in /tqüb/ ‘puncture’ → [taq<sup>o</sup>b] (H, pp. 92, 94). Geminate-final bases retain the geminate in the derived participle, hence /kübb/ ‘pour’ → [kabb], not \*[kab<sup>o</sup>b]. In tableau (24) below, we compare candidate (24a) /kabb/, [bb], with a final *single* long consonant, to (24b) \*/kab<sup>o</sup>b/, [b<sup>o</sup>b], where the base geminate has split into two /b/s coordinated with the non-overlapped pattern. As we have seen, geminate splitting is generally allowed in MCA, and there is nothing exceptional with this particular verbal stem /kübb/ ‘pour’ with respect to geminate splitting. The passive participle of /kübb/ is [m-kbub] with the geminate split. Thus, the violation of INTEGRITY in \*/kab<sup>o</sup>b/ cannot be the reason for the failure of this candidate. Rather, some other constraint also violated by \*/kab<sup>o</sup>b/ must be responsible for its suboptimality. Turning to the actual output /kabb/, its final geminate violates the structural requirement for a final sequence of two consonants – the constraint TEMPLATE, /CaCC/. Since we know that TEMPLATE ≫ INTEGRITY, we infer that there exists a constraint violated by \*/kab<sup>o</sup>b/, and that this constraint is ranked higher than TEMPLATE. This is of course CC-COORD, the constraint which is violated by any sequence of identical consonants separated by the transitional schwa, as in \*/kab<sup>o</sup>b/. Finally, candidate (24c), /kabob/, [bb], where the base geminate has split into two /b/s coordinated with the default overlapped pattern, incurs a violation of the OCP. Since, as inferred earlier OCP ≫ CC-COORD, this candidate is suboptimal.

- (24) Geminate integrity in /kübb/ ‘pour’ → [kabb], \*[kab<sup>o</sup>b]; Inferred ranking: CC-COORD ≫ TEMPLATE

Base: /kübb/	OCP	CC-COORD	TEMPLATE	INTEGRITY
a.  /kabb/ [bb]			*	
b. /kab <sup>o</sup> b/ [b <sup>o</sup> b]		*!		*
c. /kabob/ [bb]	*!			*

We may now also see why geminate splitting is possible in the cases where such splitting occurs, as in the nominal plural of /müxx/ ‘brain’, [m<sup>w</sup>xax]

or the other examples in (23). The crucial point is that, in contrast to the ‘ə’ in \*[kabəb] above, the vowel /a/ in [m<sup>w</sup>xax] is a true vowel gesture. The two /x/ consonants around /a/ in [m<sup>w</sup>xax] are not directly coordinated with one another. Rather, each consonant has its own coordination relation to the true vowel. The coordination topology for [xax] is C–V–C, with the lines denoting coordination relations. CC-COORD is not at stake here.

Finally, note that the analysis above predicts that in another dialect (or language) geminates /C<sub>x</sub>C<sub>x</sub>/ would split to final /C<sub>x</sub>≡C<sub>x</sub>/, [C<sub>x</sub>əC<sub>x</sub>] sequences. This would correspond to the ranking TEMPLATE ≫ CC-COORD. Indeed, in a brief survey of dialectal variation in the Maghreb, Heath (1991) reports three possible variants for the plural of a representative noun, /mxdd-a/ ‘pillow’: [mxadd] with geminate in-separability, [mxadəd] with geminate separability, and [mxayəd]. The first variant follows the pattern analyzed above. The template for the plural is /CCaCC/. The other two variants seem to instantiate two different ways of satisfying the templatic requirement for a final sequence of two separate consonants (not a geminate). Specifically, [mxadəd] is the form predicted by the ranking TEMPLATE ≫ CC-COORD, where temporal coordination is sacrificed to satisfy the templatic requirement for a final sequence of two consonants. The other form, [mxayəd], seems to satisfy both TEMPLATE and CC-COORD by glide epenthesis and loss of the length of the geminate in the base /mxdd-a/. Though such variation is fully compatible with our approach, and in fact it is a prediction of our analysis, a detailed inter-dialectal comparison is not possible in the present context.

To sum up, in the present dialect of MCA, the generalization that geminates /C<sub>x</sub>C<sub>x</sub>/ do not split to final [C<sub>x</sub>əC<sub>x</sub>] sequences is another consequence of temporal coordination in the grammar.<sup>11</sup>

<sup>11</sup> In MCA, there are two more cases of resistance to splitting in template mapping that cannot be examined in this paper due to space limitations. The first concerns heterorganic consonants that form a tight cluster in the base. For instance, “/disk/ ‘record’ normally has Pl /dyask/ (not \*/dyasək/)” (H, p. 105). The final two consonants of the base noun /disk/ are not coordinated with the default temporal relation dictated by CC-COORD, because the expected \*[dyasək], with the characteristic schwa-like vocalic element, is not attested (H, p. 184). This case of “cluster in-separability or integrity” can be analyzed as faithfulness to the lexically-specified temporal relation, a closed transition, of the cluster /sk/ in the base noun. The other case of clusters exhibiting resistance to splitting are homorganic nasal-stop sequences (H, p. 106). This case can be analyzed along the lines of the account for geminates given in the main text. Finally, the Damascus dialect of Syrian Arabic (Cowell 1964) provides another instance of the exceptionless generalization of geminate (in-)separability.

4.4. *Alternative Accounts*

I now consider alternative explanations for geminate in-separability based on a-temporal models of phonology. Any such model begins with the assumption that the transitional schwa in final CC clusters of templates is not a deeply phonological fact, but rather a matter of a ‘late’ epenthesis rule or a rule of phonetic implementation. Based on that assumption, we could attempt to derive the fact that a final geminate  $/C_xC_x/$  does not split to a final  $[C_x^{\circ}C_x]$  sequence by well-known mechanisms employed in auto-segmental accounts of geminate integrity. In what follows, I first illustrate an account of geminate in-separability along those lines. Then I argue that this account and the general approach on which it is based are untenable for MCA.

The basic idea of the a-temporal account is illustrated with two examples in (25). Word-formation proceeds by mapping segments to template positions. In (25a), the mapping is straightforward, associating every consonant to a C slot and the single vowel to the V slot. Then Tier Conflation (TC) linearizes the representation to give  $/taqb/$  (McCarthy 1986). This form is the output of the phonological module of MCA. At a final step, a rule of epenthesis, called Schwa Insertion (SI), applies to break up the final sequence of two consonants. The crucial point is shown in (25b). Here, the  $/l/$  is associated to two template positions. Applying Tier Conflation preserves the double-linking of the  $/l/$ , according to standard assumptions. Schwa Insertion is now blocked, because of the no-line crossing prohibition.

(25)a.  $/tq\ddot{u}b/$  ‘puncture’  $\rightarrow$   $[taq\ddot{a}b]$  (Active participle)



b.  $/H\ddot{a}ll/$  ‘open’  $\rightarrow$   $[Hall]$ ,  $*[Hal\ddot{a}l]$  (Active participle)



This view of word-formation in MCA seems to provide a straightforward account of the failure of final geminates  $/C_xC_x/$  to split to final  $[C_x^{\circ}C_x]$  sequences. Moreover, this view is neutral with respect to the nature of the inserted schwa. That schwa may be a vowel, inserted by a late epenthesis rule as assumed above, or it may be the surface manifestation of a specific

temporal relation, an open transition, between the final two consonants. This latter view of the schwa as a matter of phonetic implementation is consistent with our earlier arguments for the non-segmental nature of the schwa. If this latter view is assumed, then the phonetic implementation rule of open transition could also be prevented from applying ‘within’ a geminate for the following reason. Open transitions are inserted between two consonants or in passing from one consonant to another. Since a geminate is a single (long) segment, inserting a transition within that segment is as meaningless as inserting a transition within a non-geminate segment. Equivalently, as stated all along, CC-COORD coordinates segments. If a geminate is a single segment, CC-COORD cannot apply to insert a transition ‘within’ the geminate.

Thus the only crucial assumption of the account of geminate inseparability sketched above is that Schwa Insertion is a late epenthesis rule or a matter of phonetic implementation. This is similar to the view of Schwa Insertion implicit in Heath’s model of MCA word-formation – Schwa Insertion is a ‘post-mapping’ rule in Heath’s (1987) terms. Consider, however, the grammatical organization that the assumed view implies, namely, *Mapping* → *Tier Conflation* → *Schwa Insertion*. A consequence of this organization is that before Tier Conflation, the grammar has no access to information about *where* the vowels will eventually appear in relation to the consonants, and also no access to information about *which* vowels will appear between consonants. Yet, as I will now show, this information is absolutely crucial in determining the *Mapping* itself.

I illustrate with the diminutive [m<sup>w</sup>xiyəx], derived from /müxx/ ‘brain’, in (26a). The template has four C slots. Consonant /x/ is associated to the final (fourth) C slot of the template, but it is not associated to its preceding (third) C slot. This slot is instead filled with the glide /y/. In (26b), from agentives, however, the /b/ is associated to the fourth C slot *and* its immediately preceding C slot.

(26)a. Diminutive: /müxx/ ‘brain’ → [m<sup>w</sup>xiyəx]

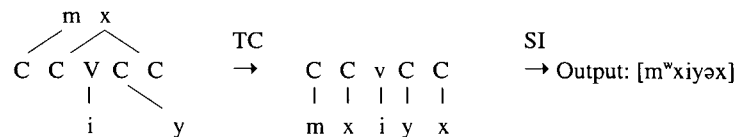

b. Agentive: /kübb/ ‘pour’ → [kbbab]





constraints in the grammar. In the second part, we have seen that alternative attempts to account for that generalization are untenable.

#### 4.5. *Initial Clusters*

Consider again the basic fact of MCA taken as the starting point of this paper. Post-vocalic clusters in templates are realized with a transitional schwa, /CCVCC/ → [CCVC<sup>ə</sup>C]. In initial or pre-vocalic CC clusters, however, the transitional schwa is not present, \*[C<sup>ə</sup>CVC<sup>ə</sup>C]. I now argue that this asymmetry in the locus of the transitional schwa is a consequence of optimization of gestural ensembles under the set of coordination relations introduced earlier (section 3).

Underlying the macroscopic characterization of an MCA template as a sequence of consonants and vowels, /CCVCC/, there is an ensemble of gestures. These gestures are orchestrated through coordination relations. The set of such relations can be thought of as defining a topology of temporal coordination, indeed as a geometry of time in the sense of Winfree (1980). To illustrate, the coordination relations present in a /CCVCC/ template are shown in (28).

(28) Coordination topology of C<sup>1</sup> C<sup>2</sup> V C<sup>3</sup> C<sup>4</sup>

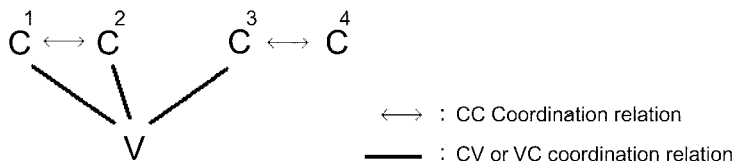

Each pre-vocalic consonant has a CV coordination relation with the vowel gesture. However, from the post-vocalic consonants, it is only C<sup>3</sup> that has a relation to the vowel – the final consonant C<sup>4</sup> is not directly related to the vowel. This is a crucial assumption which I adopt following Browman and Goldstein (1988) and subsequent experimental work on English, discussed in section 3.

Browman and Goldstein (2001) link this assumption to results from further studies showing that, as linguistic variables such as rate and prosody change, onset consonants exhibit less variability in measurements of amount of overlap than coda consonants. So in their discussion of codas, Browman and Goldstein (2001, p. 29) write: “this may help explain the greater stability that has been observed for onset consonants than for coda consonants. There is no reliable evidence that coda consonants show the c-center effect (evidence is negative in some studies or variable in others). Thus final consonants may *not* be attracted to simultaneity by a V-C

relation (parallel to the *C-V* relation). If this is correct, then there would be no need for a strong *C-C* bonding to prevent coda consonants from synchronizing” (emphasis Browman and Goldstein’s). Hence, in Browman and Goldstein’s view, it is assumed that the ‘bonding strength’ of the *C-C* relation is weaker for coda consonants. This means that *two* differences are posited between onset and coda consonants. First, every onset consonant has a *C-V* phasing relation, but only the first coda consonant has a *V-C* phasing relation. Second, the *C-C* phasing relation is weaker for coda consonants than it is for onset consonants.

I depart here from Browman and Goldstein’s analysis by proposing that only the first of these differences between onset and coda consonants is needed. There appear to be two *C-C* relations implicit in Browman and Goldstein’s analysis of the *c-center* effect. The first is the undeniable requirement for Recoverability. This is the requirement that prevents two consonants from totally overlapping each other. For reasons discussed in section 3, I assume that this is a *separate* and independent requirement from a *C-C* phasing relation, which should be the preferred pattern of coordination in *CC* clusters. This *C-C* phasing relation would have, in Browman and Goldstein’s terms, the same ‘bonding strength’ independent of whether the *CC* sequence is pre-vocalic or post-vocalic: the consonants in a *CC* onset have the same *C-C* phasing relation as the consonants in a *CC* coda. This is the coordination relation shown in (28) between the two pairs of consonants,  $C^1 \leftrightarrow C^2$  and  $C^3 \leftrightarrow C^4$ . Specifically, for MCA, this relation requires temporal coordination as in *CC-COORD*, “The *c-center* of  $C^1$ ’s oral gesture is synchronous with the onset of  $C^2$ ’s oral gesture”.

We may see now that the topology in (28) begins to explain how a transitional schwa may emerge in post-vocalic but not in pre-vocalic clusters. Consider, first, the pre-vocalic context. Each pre-vocalic *C* has a *CV* coordination relation to the *V*. Both pre-vocalic *C*s are attracted to the *V* so that apparently the preferred expression of the *C-C* relation cannot emerge between the two consonants. The *C-C* relation requires coordination as in *CC-COORD*, with the two consonants temporally distanced from each other so that an open transition [ $C^3C$ ] can be heard, for heterorganic sequences. But open transition between the consonants is in conflict with the attraction forces between these pre-vocalic consonants and the vowel. This conflict is resolved to the benefit of *C-V* coordination. The consonant gestures are overlapped more in time, as in [*CC*] with no transitional release between them.

For post-vocalic consonants, however, the situation is different. As shown in (28), because there is a *V-C<sup>3</sup>* but no *V-C<sup>4</sup>* coordination relation, the conditions banning the preferred or most temporally harmonic realiza-

tion of a CC sequence are not present post-vocally. The C<sup>3</sup>C<sup>4</sup> sequence can surface with a transitional schwa between the two consonants, the surface expression of CC-COORD. This is why the transitional schwa is seen in post-vocalic, but not in pre-vocalic clusters. The phenomenon is an instance of what McCarthy and Prince (1994) have aptly called the 'emergence of the unmarked'.

In this way, then, we can derive the presence or absence of the transitional schwa without making the assumption that the C-C relation is weaker post-vocally than pre-vocally. We may also compare this result about MCA to the case of English where final clusters as in 'bugged' [bʌgd], 'kept' [kɛpt] are produced without an intervening acoustic release. The coordination topology in the VCC environment for English is the same as that for MCA, shown in (28). The fact that there are no releases in the final clusters of English words is due to the difference in the parameter settings in CC-COORD between the two languages. English has close transition, but MCA has open transition in CC clusters (as discussed in sections 3 and 4).

We now proceed to the formal demonstration of MCA's emergent schwa. The coordination relations of (28) come with their corresponding coordination constraints. These constraints are employed to derive the asymmetry in the locus of the transitional schwa. In tableau (29), CV-COORD is the constraint which holds between each pre-vocalic C and the V, requiring that the c-center of the C be synchronous with the onset of the V, ALIGN(C, C-CENTER, V, ONSET). The constraint RECOV(ERABILITY) encodes the requirement that in a CC complete overlap between the two consonants is prohibited (Mattingly 1981; Silverman 1995). CC-COORD is the familiar MCA-specific constraint for coordination in CC clusters. The VC-COORD constraint which holds between V and C<sup>3</sup> is not crucial to the present discussion and it is not shown in (29). The example in the tableau comes from adjectival diminutives. The base is /smin/ 'fat' and the template is /CCiCC/, realized as [CCiC<sup>3</sup>C], or in this example as [smim<sup>3</sup>n] (H, p. 153). The actual output is (29b). For each candidate, under the string of segments and their coordination relations in /.../, the acoustic outputs for the pre- and post-vocalic clusters are provided. The coordination relations for each candidate are discussed immediately below.

- (29) Adjectival diminutive template /CCiCC/; Base /smin/ ‘fat’, Derived [smim<sup>ə</sup>n]; Inferred ranking: RECOV ≫ CV-COORD ≫ CC-COORD

Base: /smin/	RECOV	CV-COORD	CC-COORD
a. /s⊗m i mon/ [m] [m <sup>ə</sup> n]	*!		*(sm)
b. /s●m i mon/ [sm] [m <sup>ə</sup> n]		**	*(sm)
c. /som i mon/ [s <sup>ə</sup> m] [m <sup>ə</sup> n]		***!	

Candidates (29a, b) illustrate a conflict between RECOV and CV-COORD. In (29a), /s⊗m i mon/, the pre-vocalic consonants are coordinated with the vowel in a way that satisfies the CV-COORD constraint for each of the consonants. This entails complete overlap of the consonant gestures, indicated by /s⊗m/, which is acoustically [m] as the lips gesture hides the tip-blade gesture behind it. Thus, (29a) incurs a violation of RECOV and CC-COORD. Candidate (29b) /s●m i mon/, instead, linearizes the two consonants to save the violation of RECOV. Linearization is faithful to the order of the consonants in the base; hence /s●m/, not \*/m●s/. The constraint LINEARITY, requiring preservation of segmental order between base and derived word (McCarthy and Prince 1995b), provides the formal means to express this fact.

Let us consider the relation in /s●m/ in some detail. The pre-vocalic cluster is produced in close transition, as there is no inter-consonantal acoustic release. In what follows, I assume that the pre-vocalic cluster shows the c-center effect, as with similar clusters in English, and I describe a way that this effect can be derived from optimization of gestural ensembles.<sup>12</sup>

As we have seen with (29a), in a CCV sequence, the consonants are in conflict for coordination with the vowel. Were both consonants to establish optimal C-V timing, this would entail their complete overlap. One way to resolve this conflict is shown in (30a), where the two consonants slide

<sup>12</sup> There is no experimental evidence for this assumption as of yet in MCA. MCA may or may not exhibit the c-center effect. The existence of the c-center effect in MCA is not crucial for deriving the presence of the schwa in final CC clusters, since a different relational topology is involved post-vocally (see (28)). Whether the c-center effect is true for MCA is also not crucial for demonstrating the main point of this paper (the phonological relevance of coordination relations), since the facts relevant to template satisfaction (section 4.2) and geminate (in-)separability (section 4.3) are about final, not initial clusters.

in opposite directions with concomitant violations of their individual CV-COORD constraints.

(30) Close transition in a CCV achieved with different C-V timing relations

- a. Equal displacement of C gestures      b. Unequal displacement of C gestures

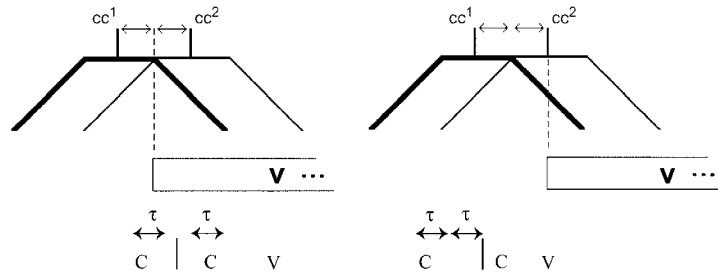

In (30a), the landmark immediately following the  $c$ -center ( $cc^1$ ) of /s/, that is, the release of /s/ is synchronous with the onset of the vowel gesture. For /m/, the landmark immediately preceding its  $c$ -center ( $cc^2$ ), that is, the target of /m/ is synchronous with the onset of the vowel gesture. Note that since the target of /m/ is synchronous with the release of /s/, the two consonants are produced in close transition, consistent with the observed acoustic output. Thus each consonant in the CCV is equally displaced from the optimal point of synchronization with the vowel. In the schematic depiction, immediately below the gestural ensemble in (30a), the vertical bar between the two Cs denotes the onset of the vowel, ' $\leftrightarrow$ ' indicates the deviation of a C's  $c$ -center from the vowel onset, and ' $\tau$ ' is the unit of temporal distance, which is taken to be the distance between between  $c$ -center and release, or, equally, between target and  $c$ -center. Each consonant in a CCV incurs one violation of CV-COORD. Thus, in tableau (29), candidate (29b) is assigned two violation marks under CV-COORD.

However, (30a) is not the only way to achieve close transition between /s, m/. An alternative with the same acoustic consequence, a close transition, is depicted in (30b). Here, /m/ is optimally coordinated with the vowel, that is, the  $c$ -center of /m/, shown as  $cc^2$ , is synchronous with the onset of the vowel. Close transition is maintained in /s, m/, as it is still the release of /s/ that is synchronous with the target of /m/. This candidate incurs the same number of violations as the assumed optimal one (30a). Specifically, (30b) incurs two violations of CV-COORD due to the first consonant, but no violations for the second consonant. The difference between (30a,b) is qualitative. In (30a), the temporal disharmony is equally dispersed between the two consonants. Instead, (30b) is maximally harmonic

with respect to the second consonant, localizing the temporal disharmony entirely on the first consonant.

Smolensky (1993, 1995, 1997) has argued that two constraint violations are worse when they occur locally than when they occur non-locally. This idea appears to be useful in capturing patterns of optimization in a wide range of cases (see Smolensky 1993, 1995, 1997, on segmental markedness, sonority profiles, and vowel harmony, respectively; Itô and Mester 1997; Alderete 1997 on dissimilation; Gafos and Lombardi 1999 on consonant transparency; Kiparsky 2000 on vowel harmony, among others). To express this property of constraint violation, Smolensky has proposed that the constraint component of an OT grammar includes “an operation in UG by which two constraints governing substructures of a given local domain are conjoined into a higher ranked constraint” (Smolensky 1993). This operation, called Local Conjunction, is defined as shown below.

- (31) The Local Conjunction of  $C_1$  and  $C_2$  in domain  $D$ :  $C_1 \&_l C_2$ , is violated when there is some domain of type  $D$  in which both  $C_1$  and  $C_2$  are violated. Universally,  $C_1 \&_l C_2 \gg C_1, C_2$ .

When  $C_1$  and  $C_2$  are the same constraint  $C$ , the operation is called *self-conjunction*, and it is denoted by  $C\&C \equiv C^2 \gg C$ . Letting the constraint in the operation of self-conjunction be CV-COORD, we have  $CV-COORD^2 \gg CV-COORD$  (the local domain is the segment). The candidate (30b) with unequal displacements incurs one violation of  $CV-COORD^2$ , whereas the optimal candidate with equal displacements incurs (two) violations of the lower ranked CV-COORD, but no violation of the locally conjoined constraint precisely because the displacement violations are distributed equally through the CC cluster. It follows that the former candidate is sub-optimal. Equal displacement, (30a), is preferred over unequal displacement, (30b).

This concludes the discussion of the pre-vocalic context in candidate (29b) /s●m i mon/. The post-vocalic cluster of this candidate is /mon/ with the two consonants coordinated as in CC-COORD. Since (29b) is the assumed output, a comparison of (29a, b) allows us to infer that RECOV  $\gg$  CV-COORD. Intuitively, this ranking expresses the fact that when two consonants are part of an onset, optimal coordination with the tautosyllabic vowel is sacrificed to ensure recoverability.

The other pair of conflicting constraints in tableau (29) is illustrated by candidates (29b, c). In (29c), /som i mon/, the pre-vocalic consonants are distanced farther apart than in (29b), /s●m i mon/. This allows for the schwa to surface pre-vocalically, hence [s<sup>3</sup>m] for (29c). The timing in the pre-vocalic cluster now satisfies CC-COORD, but it also results in

more violations of CV-COORD than those of (29b), because the two consonants in (29c) are less overlapped than in (29b). As was the case with close transition in a CCV, discussed around (30), open transition between the two consonants in a CCV can be achieved under various C-V timing configurations. But (29c)'s cumulative CV-COORD violations are bound to be greater than those of (29b), because the consonants overlap less in (29b) than in (29c). Since (29b) is the assumed output, we infer that CV-COORD  $\gg$  CC-COORD.

This concludes the account of the asymmetry in the locus of the transitional schwa, namely, the fact that the schwa appears in post-vocalic clusters at the ends of templates, but not in pre-vocalic clusters. We can now turn to consider one exception to this distribution. In a language game Heath calls 'PS-inv', speakers produce a disguised version of an actual word by inverting the order of consonants in the stem. In general, affixes remain intact by this inversion. For example, the variant of the actual word [ta-y-gləs] 'he sits' is [ta-y-sləg] and the variant of [blaS-t-i] 'my place' is [Slab-t-i]. The game is also applicable to words formed on templates, as for example with the plurals [blay<sup>ə</sup>S] 'places' and [Hway<sup>ə</sup>ž] 'things', formed on the /CCVCC/ template, with the game forms [Slay<sup>ə</sup>b] and [Hyaw<sup>ə</sup>ž], respectively. The crucial fact is illustrated with stems that include two identical consonants: [Hlilu] 'sweet.diminutive' surfaces in this game as [l<sup>^</sup>liHu], [Hbib] 'maternal uncle' as [b<sup>^</sup>biH], and [xmməm] 'he thought' as [m<sup>^</sup>mməx]; the symbol '^' here denotes an intervening release (H, p. 186; cf. footnote 3 on the use of '^'). This is the only instance known to me where two identical consonants are brought to contiguity in the *initial* CC cluster of a CCV sequence (for final CCs, the phenomenon is discussed in sections 4.2–3). This is also the only instance where a transitional release appears in a pre-vocalic context. In this context, CV-COORD favors a close transition, as discussed in (30a) above. But close transition between identical consonants implies a violation of the OCP. Thus CV-COORD is in conflict with the OCP here. The observed open transition argues for a new ranking relation, OCP  $\gg$  CV-COORD.

The overall constraint hierarchy is RECOV, OCP  $\gg$  CV-COORD  $\gg$  CC-COORD. In this section, we have seen consequences of the ranking between every pair of constraints in this hierarchy except for OCP  $\gg$  CC-COORD. The consequences of this latter ranking were discussed in sections 4.1–3.

#### 4.6. *Inter-vocalic Clusters*

I have discussed effects of gestural coordination in CC clusters at template-initial and -final position, as in the active participle /CaCC/, the nominal plural /CCaCC/, and the adjectival diminutive /CCiCC/. In this section,

I address CC clusters in inter-vocalic position, within a template. Independent of their profile as heterorganic or homorganic, these show no transitional schwa.

The main source of inter-vocalic clusters within a template is the professional noun /CCaCC-i/. Representative examples include: /žurnal/ ‘newspaper’ → [žRanl-i], not \*[žRan<sup>o</sup>l-i], /s<sup>w</sup>kkar/ ‘sugar’ → [skakR-i], not \*[skak<sup>o</sup>R-i], /Sbbən/ ‘wash clothes’ → [Sbabn-i], not \*[Sbab<sup>o</sup>n-i], and /brquq/ ‘plums’ → [braqq-i], not \*[braq<sup>o</sup>q-i] (H, pp. 140–141). The inter-vocalic clusters in these examples, then, show no acoustic release, [VCCV], not \*[VC<sup>o</sup>CV]. This seems true for CC clusters in other templates that sometimes appear with a vowel suffix. For example, consider the nominal diminutive template /CCiCC/ in which some derived words take the feminine suffix /-a/, as in /bab/ ‘door’ → [bwiyb-a], but also [bwiy<sup>o</sup>b], without the suffix (H, pp. 114–115). Thus, when the derived word ends in a cluster, the transitional schwa emerges, but the suffixed version of the same word shows no schwa.

To understand this phenomenon, we must consider the coordination topology for inter-vocalic clusters. We begin with the topology for a final VC<sup>1</sup>C<sup>2</sup> sequence, in (32a). Adding a vowel alters this topology by adding new coordination relations as in (32b). As with an initial CCV sequence, there are two C-V relations, one for each consonant in the C<sup>1</sup>C<sup>2</sup> cluster. Adding a vowel, then, constrains the coordination topology further by adding new temporal relations. Consequently, the default coordination pattern observed in final CC clusters fails to emerge in inter-vocalic CC clusters. More formally, as we have seen, optimizing C<sup>1</sup>C<sup>2</sup>V in (32b) under the ranking CV-COORD ≫ CC-COORD effects a close transition in the C<sup>1</sup>C<sup>2</sup> cluster. The C<sup>1</sup>C<sup>2</sup>V subset of (32b) does not interact optimization-wise with the VC<sup>1</sup> subset. The two share C<sup>1</sup>, but the VC<sup>1</sup>- and C<sup>1</sup>V-COORD constraints do not conflict.

- (32) Close transition in a CCV achieved with different C-V timing relations

a. VCC-final template

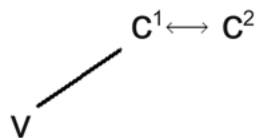

b. VCC – V (preliminary)

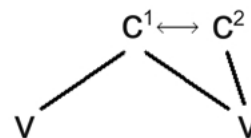

Hence, (32b) accounts for the absence of the release in a inter-vocalic sequence of two heterorganic consonants. The coordination relation between the two consonants was inferred in section 4.5, and is repeated here in (33).

The close transition can be seen by the fact that the release of the first C coincides with the target of the second C, that is, /C●C/. The dashed lines depict V-C or C-V relations. For the C-V relations, the onset of the second V coincides with the release of C<sup>1</sup> and the target of C<sup>2</sup> (see section 4.5).

- (33) Coordination in two heterorganic consonants in a VC<sup>1</sup>C<sup>2</sup>V:  
absence of release

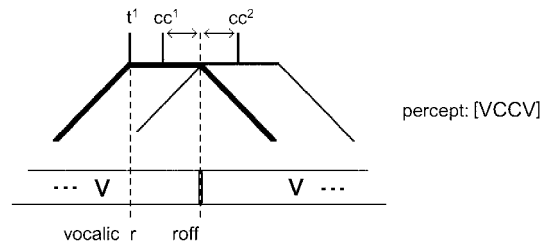

As can be seen above, in the V-C<sup>1</sup> relation, the landmark designated as vocalic r, the release of the vowel, is synchronous with the target t<sup>1</sup> of C<sup>1</sup>, as required by VC-COORD. Note that, as a result of this V-C timing, the end of the activation window for the first vowel, the release offset of this vowel, is shown to coincide with the release of C<sup>1</sup>. This is a consequence of an assumption made here that the inter-landmark distance for vowels is the same as that for consonants. That is, the distance  $\Delta$  between the release and the release offset landmarks for a V is the same as the distance between the target and the release of a C. This is a simplification. The only essential assumption here is that, in a VCCV, there is *some* overlap of the two vowels. That is, in a VCCV, the vowels are contiguous much as they would be in a VV sequence. This assumption derives from work on vowel-to-vowel coarticulation, starting with the seminal study of Öhman (1966). Öhman observed that consonant gestures are superimposed on a continuous vocalic substrate and that, during the production of consonant gestures, there is a smooth transition from the articulatory configuration of the first V to that of the second V (see also Fowler 1983; Gafos 1996). The assumption of V-to-V contiguity is put to work immediately below.

Consider now the noun /bRquq/ 'plum'. Its professional noun, formed on the template /CCaCC-i/, is [bRaqq-i] 'dealer in plums'. Heath reports: "Elicitation sessions involving /bRaqq-i/ suggested that speakers do have a mental representation of this output as //bRaqq-i// or at least //bRaqq-i// with the symbol ^ specifying separate articulation and release of the identical Cs. The primary informant stated this quite explicitly and voluntarily: 'it is as though you are trying to say [bRaqq-i] but it comes out as [bRaqq-i]' " (p. 146). As with heterorganic clusters, then, clusters of

identical consonants show no *acoustic* release in the inter-vocalic context, [bRaqq-i]. The two identical consonants must overlap. This outcome is unexpected given the coordination relations employed up to now. To see this, recall that in the only instance where identical consonants appear pre-vocalically, the game 'PS-inv', the CC cluster is produced in open transition: /Hbib/ 'maternal uncle' → /b<sup>≡</sup>biH/, [b<sup>ə</sup>biH]. This open transition was analyzed as the effect of the ranking OCP ≫ CV-COORD. Turning to an inter-vocalic cluster, VCCV, the situation is similar. Recall that the C<sup>1</sup>C<sup>2</sup>V part of (32b) does not interact optimization-wise with the VC<sup>1</sup> part. So far, then, if the inter-vocalic topology is as in (32b), it falsely predicts open, not close, transitions between identical consonants, as in \*/braq<sup>≡</sup>qi/, given the ranking OCP ≫ CV-COORD.

Thus, some other constraint must be enforcing the close transition observed in [bRaqq-i]. The crucial difference between \*/braq<sup>≡</sup>qi/ and /b<sup>≡</sup>biH/ is that, in the former, the identical consonants are in inter-vocalic context, but in the latter they are at an edge. I propose that, in the inter-vocalic context, an additional coordination relation V-V is involved. Its corresponding constraint VV-COORD requires overlap of consecutive vowels. Minimally, this constraint requires that the release offset of the first V is synchronous with the onset of the second V, ALIGN(V, ONSET, V, RELEASE-OFFSET). A plausible basis of this constraint can be found in the phenomenon of V-to-V contiguity discussed earlier. Stating VV-COORD as a grammatical requirement further assumes that V-V timing is independently controlled as part of the rhythmic organization of utterances. Concrete evidence for this assumption derives from work by Smith (1991, 1993). Smith presents evidence that, in Italian, the timing of vowels is unaffected by the length of the intervening consonantal period. That is, VpV and VppV utterances show a virtually identical time-course of vowel-to-vowel movements. This supports the hypothesis that, in Italian, V-V timing is controlled independently from V-C or C-V timing. In contrast to Italian, Smith finds that, in Japanese, increasing the inter-vocalic consonantal duration does affect vowel-to-vowel timing. Thus, in a Vp(p)V, the second vowel is significantly more delayed when following the geminate in VppV than when following the single in VpV (see also Maddieson 1985, 1997). Smith conjectures that this difference between the two languages is the basis for the rhythmic patterns of 'syllable-timed' versus 'mora-timed' languages. In the present context, Smith's work suggests that languages may employ different coordination topologies, so that a V-V relation is present in Italian, but not in Japanese, where the timing of vowels is mediated by the intervening consonants.

Let us then revise the VCCV topology by adding the V-V relation, as in (34a). Its projected constraint VV-COORD demands overlap of the vowels, thus constraining further the possible timing relations in inter-vocalic CC clusters. Effectively, in the inter-vocalic context, local compression between two identical consonants as in /q•q/, acoustically [qq], is required to maintain V-to-V contiguity (in /Vq•qV/, V-to-V contiguity is achieved as in 33). That is, the OCP violating /Vq•qV/ is preferred over the VV-COORD violating \*/Vq≐qV/. The reason why \*/Vq≐qV/, acoustically \*[Vq<sup>o</sup>qV], violates VV-COORD can be seen in (34b). If the inter-vocalic consonants were timed as in /q≐q/, the vowel gestures would shift apart along with their associated consonants, breaching V-to-V contiguity.

- (34)a. Revised VCCV topology    b. Breaching V-to-V contiguity in \*/VC≐CV/

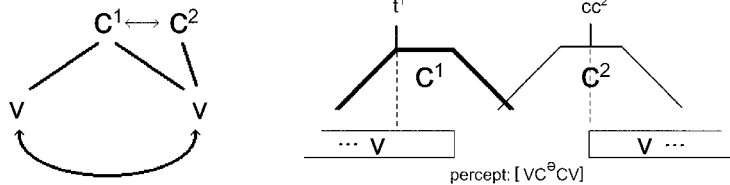

We may thus infer the ranking VV-COORD  $\gg$  OCP. The final constraint hierarchy of the gestural coordination constraints discussed is RECOV, VV-COORD  $\gg$  OCP  $\gg$  CV-COORD  $\gg$  CC-COORD.

To sum up, inter-vocalic CC clusters do not show the coordination pattern of CC-COORD. For heterorganic, inter-vocalic clusters such as [Sbavn-i] ‘washer’, this follows from optimization of the coordination topology under the familiar constraints, in particular, under the ranking CV-COORD  $\gg$  CC-COORD, whose effects are also observed in the pre-vocalic context. For clusters of identical consonants, the situation is more interesting. In contrast to the open transition observed between identical consonants at the edges, as in /b≐biH/ and /ZnaT≐T/, open transition is impossible inter-vocalically, \*/braq≐qi/. The edges are precisely the contexts where vowel-to-vowel contiguity, the requirement of VV-COORD, is not in effect. Consequently, it is at the edges where OCP effects emerge and identical consonants slide away from each other. Between two vowels, however, such sliding would imply breaching of V-to-V contiguity. The statement of this requirement in the grammar, VV-COORD, masks the effects of the OCP and enforces a close transition in this context.

#### 4.7. *Recapitulation of the Main Argument*

An a-temporal model of phonology is agnostic about the properties discussed in sections 4.5–4.6, concerning release distribution in pre-, post-, and inter-vocalic CC sequences. These properties refer to temporal coordination of gestures. By definition, a-temporal phonological representations lack the relevant dimensionality. That being true, however, we may still attempt to conceive of a model where such properties derive from a system of ‘phonetic implementation’. Temporal dynamics would be an aspect of that system. Furthermore, insisting on the standard view of an a-temporal phonology, temporal information would *not* be an aspect of the phonological representation, and consequently also not an aspect of the grammar involved in deriving the higher-level or ‘phonological’ properties of the language. But consider: the forces responsible for the transitional schwa in final CC sequences *are* intimately involved in explaining an assembly of phonological properties of MCA templates. Put differently, in words familiar from the argument running throughout sections 4.1–4.4, those same forces generating the schwa have higher-level consequences for the phonology of the language. This state of affairs is simply inexpressible in a-temporal phonology. To get back to the main theme, phonological representation must include information about the temporal orchestration of gestures. Constraints in the grammar directly refer to that aspect of the representation.<sup>13</sup>

The most important precursor to temporal orchestration in phonology is the notion of ‘association line’ of autosegmental phonology. The basic fact established in the autosegmental model is that articulators act independently in phonologically relevant ways. This necessitates an orchestration scheme for the articulators. Orchestration is encoded by association lines.

<sup>13</sup> In MCA, there is a class of nouns which take the shape /CəCC/, and which show systematic absence of the transition in the final cluster. These nouns are related to corresponding verbs: /DHək/ ‘to laugh’ ~ /DəHk/ ‘laughter’, /Drəb/ ‘to hit’ ~ /Dərb/ ‘hitting’, /knəz/ ‘to treasure’ ~ /kənz/ ‘a treasure’, /wləd/ ‘to give birth’ ~ /wəld/ ‘a boy’. Heath (p. 265) writes that these nouns, “while still reasonably plentiful, are basically an archaic stratum in the lexicon; recall for example, that the /CəCC/ verbal noun has given way to a productive new type in /CCiC/.” In our approach, one interpretation of the absence of the transition in /CəCC/ is that this template requires a specific coordination relation between the two final consonants, a close transition, which is different from that of the other templates, e.g., the noun plural /CCaCC/ template or the adjectival diminutive /CCiCC/ template, both of which show the characteristic open transition in the final cluster. If, as claimed here, temporal coordination is part of the representation, then we may expect to find morphology that expresses itself, partially or totally, through that aspect of the representation (“temporal morphology”). I will not pursue this line further in this paper. I thank Michael Kenstowicz for pointing out to me this fact about /CəCC/ verbal nouns.

In Goldsmith's words, "autosegmental phonology is a theory of how the various components of the articulatory apparatus ... are coordinated" (1976, p. 23). In Sagey's words, "association lines imply some degree of coordination in time" (1986, p. 289). What does coordination mean in this context? Association lines link features [F] to skeletal X slots. Sagey argues that these associations encode overlap in time between elements that have internal duration: "features and x-slots have internal duration" (p. 112). Thus "features and x-slots are no longer unanalyzable units ... but instead are made up of points of time" (p. 290). However, Sagey also writes that "I assume that the points of time within a feature or x-slot are accessible only at the late level of phonetic implementation, where quantitative rules may apply, and that they are not manipulable or accessible by phonological rules" (p. 293 and also p. 310).

As argued in this paper, expression of qualitative aspects of phonological form rests on the ability of the grammar to refer to the internal temporal structure of gestures. This necessitates a different coordination scheme from that of association lines and a revision of the view that gestural coordination is 'phonetic implementation' or 'low-level mechanics of speech articulation.' If, as argued here, linguistic grammars, the most remarkable aspect of our cognitive abilities, are constructed in part out of *patterns of gestural coordination*, it follows that those patterns are deeply cognitive.

##### 5. ALTERNATIVE COORDINATION SCHEMES

I have so far taken it for granted that gestural orchestration is effected via constraints of a specific nature. The grammatical constraints I proposed relate *landmarks within the internal temporal structure of the gestures* being coordinated. The question arises as to whether it is possible to express the same facts using alternative conceptions of coordination and, consequently, alternative models of phonology.

Recall the basic fact from which the analyses in section 4 begin: there is an acoustic release between the two final consonants in templates, independent of their profile as identical or heterorganic, [Zna<sup>o</sup>T<sup>o</sup>T] 'tail.plural' or [smim<sup>o</sup>n] 'hot.diminutive', respectively. Considerable attention has been devoted to the importance and the role of releases in various models of phonology (McCawley 1972; Anderson 1974; Selkirk 1982; Kingston 1985; Kim-Renaud 1986; Steriade 1993, 1994; Padgett 1997). This suggests an alternative view of the facts. Suppose coordination relations are expressed along the lines of statements like '(do/do not) have an acoustic release between two consonants'. We may call this coordination alternative

‘acoustically-driven’ coordination to emphasize the fact that the goals of coordination schemes are now acoustic in nature, establishing relations that ‘end-gain’ for target events in an acoustic space. Presumably some equivalence class of such relations defined at the articulatory plan level would generate the acoustic releases. The proper definition of what that class actually is must undoubtedly take into account things such as whether the two consonants in a CC sequence are identical or heterorganic (recall that in [d<sup>o</sup>d], [b<sup>o</sup>d] the coordination relations are different). But all this happens at a lower, executive level whose primitives are inaccessible to phonology. The phonological grammar is only concerned with the presence or absence of acoustic releases. Gestural plans follow suit.

The MCA facts are a challenge for the acoustically-driven view of coordination. If, following that view, we require that in final CC clusters there is release between the two consonants, then a range of properties would be unexplained. Recall that in MCA separate but identical consonants avoid clustering in final CC clusters of templates. This fact is involved in a range of phenomena which include things like the default medial duplication seen in /smin/ ‘fat’ → [smim<sup>o</sup>n], \*[smin<sup>o</sup>n], and deviations from that default in stems like /rqi/ ‘thin’ → [rqi<sup>o</sup>q], \*[rqi<sup>o</sup>q]. But if all that the grammar requires is a release in final CC clusters, the unattested candidates would be just as well-formed as the attested ones. In each case, there is an acoustic release between the two final consonants.

Consider also the distribution of releases in CC clusters of MCA templates, summarized in (35), for the three contexts, post-vocalic vCC, pre-vocalic CCv, and inter-vocalic vCCv, and for two types of clusters, heterorganic and identical. It can be seen that releases are suppressed in contexts where requirements such as vowel-to-vowel contiguity and overlap between consonants and vowels seem independently motivated. For example, heterorganic consonants show a release in the post-vocalic, but not in the pre-vocalic context, due to the presence of an additional C-V relation; and identical consonants, in pre- and post-vocalic contexts, must be produced with an intervening release, but this release is not present in an inter-vocalic sequence of consonants. The inter-vocalic context is temporally the most constrained context, as vowels appear on both sides of the consonant cluster, (35b).

## (35)a. Release distribution and its grammar

	<u>Heterogonic</u> : b, d		<u>Identical</u> : t, t	
<u>vCC</u>	/bod/, [b <sup>o</sup> d]	CC-COORD	/t <sup>o</sup> t/, [t <sup>o</sup> t]	OCP ≫ CC-COORD
<u>CCv</u>	/b <sup>o</sup> d/, [bd]	CV-COORD ≫ CC-COORD	/t <sup>o</sup> t/, [t <sup>o</sup> t]	OCP ≫ CV-COORD
<u>vCCv</u>	/b <sup>o</sup> d/, [bd]	CV-COORD ≫ CC-COORD	/t <sup>o</sup> t/, [tt]	VV-COORD ≫ OCP

## b. Topologies

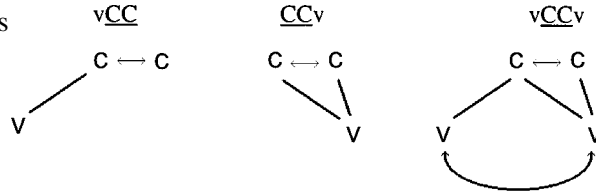

## c. Coordination relations (in 35a)

- C<sub>o</sub>C**: The *c-center* of the first gesture is synchronous with the *onset* of the second gesture
- C<sub>•</sub>C**: The *release* of the first gesture is synchronous with the *target* of the second gesture
- C<sub>⇐</sub>C**: The *release offset* of the first gesture is synchronous with the onset of the second gesture

To express the generalization that releases are progressively suppressed as more temporal constraints are added seems to require a formal statement of what it means for consonants and vowels to overlap or to be related to one another in time; this is exactly what coordination constraints, as proposed here, provide. But coordination instructions concerned only with the presence or absence of acoustic releases are statements at another level of description. The core assumption of the acoustically-driven coordination view is that the ‘executive’ level of implementing the release (or absence thereof), via proper alignment of gestural units, is inaccessible to phonology. Consequently, the generalization that the presence or absence of release correlates with the temporal complexity of the context is inexpressible within such a view.

More generally, ascribing the presence of the release to constraints like ‘Have acoustic release’ says nothing about the coordination plan that would generate that release. As seen, however, a range of phenomena such as (a) disappearance of the release in [b<sup>o</sup>d] when produced at a fast rate but persistence of the release in [t<sup>o</sup>t] under the same rate conditions, (b) possibility of a release in post-vocalic clusters, (c) impossibility of a release in pre-vocalic clusters and exceptions to this, (d) absence of a release in medial clusters, (e) geminate integrity in final CC clusters, and (f) properties

of the default fill-in mechanisms in templates and exceptions to these, all crucially derive from coordination constraints that state relations between gestures by reference to the internal temporal structure of these gestures. It is not at all obvious how the acoustically-driven coordination alternative could relate the assembly of these phenomena to one another in the way done here using constraints on gestural coordination.

## 6. CONCLUSION

There is a time-honored assumption within phonology and phonetics that the temporal dimension of speech is irrelevant to the qualitative aspects of phonological organization. This assumption is remarkably prevalent across different theoretical views. Anderson (1994) writes: “phonologists have until quite recently worked hard to develop models in which there is literally no place for the details of the time course . . . . A widespread (but completely unsupported) assumption among phonologists is that it is precisely in this domain that we can attribute everything we observe to the (language-independent) mechanics of speech articulation”. Building on the notions gesture and gestural coordination (Browman and Goldstein 1986 et seq.), the main concern of this paper has been the construction of the argument that the phonological grammar is involved in the temporal orchestration of gestures. The temporal dimension is threaded in the phonological representation via coordination relations. It was argued that such relations and their corresponding grammatical constraints are determinant of the qualitative aspects of phonological form. We may thus speak of a grammar of gestural coordination. The proposed model for such a grammar has been illustrated by an analysis of aspects of the phonological system of a dialect of Moroccan Colloquial Arabic. It was argued that aspects of MCA’s phonological form are embodied in characteristic patterns of gestural coordination which are deeply the concern of the grammar. It was also argued that a-temporal models of phonology cannot deal adequately with the facts presented.

Though this paper is about time, it is emphasized that the phonologically relevant notion of time proposed is different from real-time. Specifically, the constraints on gestural coordination introduced here do not refer to notions of real-time as in scales of milliseconds or absolute durations. The main motivation for this derives from the observation that the spatio-temporal units that make up the phonology of a language show a remarkable stability under variations in speaking rate and other extra-grammatical conditions. Witness, for example, the fact that the means of template satisfaction in MCA do not change as speakers articulate faster.

At the same time, I have argued explicitly that template satisfaction in MCA crucially relies on the temporal organization of gestures. It follows that the grammar must compute free of any notions of absolute time. If a notion of time is part of phonology, it must be fundamentally relative. This is a solidly justifiable notion of time in cognition (Winfree 1980; Turvey 1990; Churchland and Sejnowski 1993, chapter 6). In contrast, the hypothesis that notions of absolute time are part of cognition correspond to what Port et al. (1995) refer to as “naive theories of time”, which are cognitively and biologically implausible.

More generally, the claim that ‘time is part of the phonological representation’ does not imply a ‘physicalist’ view of phonology. Tracing the development of the present argument will make this point clearer. We began with the observation that linguistic form is expressed not only in space but also in time. It is thus entirely natural to expect that linguistic form is as grounded in the temporal dimension as it is in the spatial one. In the process of pursuing this expectation, however, we find that the phonologically relevant notion of time is rather abstract. It has little to do with time scales measured in milliseconds. It is a relational notion of time. Indeed it can be described as geometric, with lines connecting the two landmarks in the internal temporal structure of the coordinated gestures. Moreover, this notion of time is not directly observable from the superficial physics of the signal. Recall that in both [t<sup>9</sup>t] and [t<sup>9</sup>b] there is a release, but the underlying temporal coordination is crucially different. At the core of the argument, of course, is the demonstration that this is the notion of time that provides the best fit to the data discussed herein. Last but not least, this relational notion of time is biologically plausible. All along then, I have tried to show that there is a more subtle relationship between the low-level dynamics of speech and the higher-level, qualitative aspects of phonological form. The end product is something of a mutual fit between the ‘abstract’ and the ‘physical’.

Mental facts cannot be properly studied apart from the physical environment of which they take cognisance . . . our inner faculties are adapted in advance to the features of the world in which we dwell, adapted, I mean, so as to secure our safety and prosperity in its midst . . . . Mind and world in short have evolved together, and in consequence are something of a mutual fit. (William James 1892, pp. xxvii–xxviii)

#### REFERENCES

- Abraham, Ralph H. and Christopher D. Shaw. 1982. *Dynamics – The Geometry of Behavior*, Aerial Press, Santa Cruz, CA.

- Alderete, John. 1997. 'Dissimilation as Local Conjunction', in Kiyomi Kusumoto (ed.), *Proceedings of NELS 27*, GLSA, University of Massachusetts, Amherst, pp. 17–31.
- Anderson, Stephen R. 1974. *The Organization of Phonology*, Academic Press, New York.
- Anderson, Stephen R. 1994. 'Phonetic Representation: What's in It for You?', unpublished manuscript, Department of Cognitive Science, Johns Hopkins University, Baltimore.
- Beckman, Mary E., Jan Edwards and Janet Fletcher. 1992. 'Prosodic Structure and Tempo in a Sonority Model of Articulatory Dynamics', in Gerard J. Docherty and D. Robert Ladd (eds.), *Papers in Laboratory Phonology II: Gesture, Segment, Prosody*, Cambridge University Press, Cambridge, pp. 68–86.
- Berkley, Deborah. 1994. 'The OCP and Gradient Data', *Studies in the Linguistic Sciences* **24**, 1–14.
- Bird, Steven. 1995. *Computational Phonology: A Constraint-Based Approach*, Cambridge University Press, Cambridge.
- Bloomfield, Leonard. 1933. *Language*, Holt, Rinehart and Winston, New York.
- Browman, Catherine P. 1994. 'Lip Aperture and Consonant Releases', in Patricia Keating (ed.), *Phonological Structure and Phonetic Form, Papers in Laboratory Phonology III*, Cambridge University Press, Cambridge, pp. 331–353.
- Browman, Catherine P. and Louis Goldstein. 1986. 'Towards an Articulatory Phonology', *Phonology* **3**, 219–252.
- Browman, Catherine P. and Louis Goldstein. 1988. 'Some Notes on Syllable Structure in Articulatory Phonology', *Phonetica* **45**, 140–155.
- Browman, Catherine P. and Louis Goldstein. 1989. 'Articulatory Gestures as Phonological Units', *Phonology* **6**, 201–251.
- Browman, Catherine P. and Louis Goldstein. 1990a. 'Tiers in Articulatory Phonology, with some Implications for Casual Speech', in John Kingston and Mary Beckman (eds.), *Papers in Laboratory Phonology I: Between the Grammar and the Physics of Speech*, Cambridge University Press, Cambridge, pp. 341–397.
- Browman, Catherine P. and Louis Goldstein. 1990b. 'Gestural Specification Using Dynamically-Defined Articulatory Gestures', *Journal of Phonetics* **18**, 299–320.
- Browman, Catherine P. and Louis Goldstein. 1992. 'Targetless Schwa: An Articulatory Analysis', in Gerard Docherty and D. Robert Ladd (eds.), *Papers in Laboratory Phonology II: Gesture, Segment, Prosody*, Cambridge University Press, Cambridge, pp. 26–56.
- Browman, Catherine P. and Louis Goldstein. 1995. 'Dynamics and Articulatory Phonology', in Robert F. Port and Timothy van Gelder (eds.), *Mind as Motion*, MIT Press, Cambridge, MA, pp. 175–193.
- Browman, Catherine P. and Louis Goldstein. 2001. 'Competing Constraints on Intergestural Coordination and Self-Organization of Phonological Structures', *Les Cahiers de l'ICP, Bulletin de la Communication Parlée* **5**, 25–34.
- Buckley, Eugene. 1990. 'Edge-in Association and OCP 'Violations' in Tigrinya', in Aaron Halpren (ed.), *Proceedings of the West Coast Conference in Formal Linguistics 9*, CSLI, Stanford, pp. 75–90.
- Byrd, Dani. 1994. *Articulatory Timing in English Consonant Sequences*, unpublished Ph.D. dissertation, University of California, Los Angeles.
- Catford, John S. 1977. *Fundamental Problems in Phonetics*, Edinburgh University Press, Edinburgh.
- Catford, John S. 1988. *A Practical Introduction to Phonetics*, Clarendon Press, Oxford.
- Chomsky, Noam and Morris Halle. 1968. *The Sound Pattern of English*, Harper and Row, New York.

- Churchland, Patricia, S. and Terrence J. Sejnowski. 1993. *The Computational Brain*, 2nd edn, MIT Press, Cambridge, MA.
- Clements, G. N. 1985. 'The Geometry of Phonological Features', *Phonology Yearbook* **2**, 225–252.
- Clements, G. N. 1991. 'Vowel Height Assimilation in Bantu Languages', in *Working Papers of the Cornell Phonetics Laboratory*, Vol. 5, Cornell University, Ithaca, NY, pp. 37–76.
- Cowell, Mark W. 1964. *A Reference Grammar of Syrian Arabic [based on the dialect of Damascus]*, Georgetown University Press, Washington, D.C.
- Dell, François and Mohamed Elmedlaoui. 1996. 'On Consonant Releases in Imdlawn Tashlhiyt Berber', *Linguistics* **34**, 357–395.
- Elson, Ben. 1947. 'Sierra Popoluca Syllable Structure', *IJAL* **13**, 13–17.
- Fowler, Carol. 1983. 'Converging Sources of Evidence for Spoken and Perceived Rhythms of Speech: Cyclic Production of Vowels in Sequences of Monosyllabic Stress Feet', *Journal of Experimental Psychology* **112**, 384–412.
- Gafos, Adamantios I. 1996. *The Articulatory Basis of Locality in Phonology*, Ph.D. dissertation, Johns Hopkins University, Baltimore, MD. [Published 1999, Garland, New York.]
- Gafos, Diamandis. 1998. 'Eliminating Long Distance Consonantal Spreading', *NLLT* **16**, 223–278.
- Gafos, Adamantios I. and Linda Lombardi. 1999. 'Consonant Transparency and Vowel Echo', in P. Tamanji, M. Hirotani and N. Hall (eds.), *Proceedings of NELS 29*, GLSA, University of Massachusetts, Amherst, pp. 81–96.
- Goldsmith, John. 1976. 'An Overview of Autosegmental Phonology', *Linguistic Analysis* **2**, 23–68.
- Goldsmith, John. 1995. *Handbook of Phonological Theory*, Blackwell, Oxford.
- Guerssel, Mohamed. 1977. 'Constraints on Phonological Rules', *Linguistic Analysis* **3**, 267–305.
- Guerssel, Mohamed. 1978. 'A Condition on Assimilation Rules', *Linguistic Analysis* **4**, 225–254.
- Halle, Morris. 1983. 'On Distinctive Features and Their Articulatory Implementation', *NLLT* **1**, 91–105.
- Halle, Morris. 1995. 'Feature Geometry and Feature Spreading', *Linguistic Inquiry* **26**, 1–46.
- Hayes, Bruce P. 1986. 'Inalterability in CV Phonology', *Language* **62**, 321–351.
- Heath, Jeffrey. 1987. *Ablaut and Ambiguity: Phonology of a Moroccan Arabic Dialect*, State University of New York Press, Albany.
- Heath, Jeffrey. 1991. 'Moroccan Arabic Plurals and Gemination: Some Data to Sleep On', in Kaye (1991), pp. 627–633.
- Hoberman, Robert. 1992. 'Local Spreading', *Journal of Afroasiatic Linguistics* **3**, 226–254.
- Honorof, Douglas N. and Catherine P. Browman. 1995. 'The Center or the Edge: How Are Consonant Clusters Organized with Respect to the Vowel?', in K. Elenius and P. Branderud (eds.), *Proceedings of the XIIIth International Congress of Phonetic Sciences*, Vol. 3, Stockholm, Sweden, pp. 552–555.
- Hyman, Larry M. 1985. *A Theory of Phonological Weight*, Foris, Dordrecht.
- Itô, Junko and Armin Mester. 1997. 'Markedness and Word Structure: OCP Effects in Japanese', unpublished manuscript, University of California at Santa Cruz, CA. [Also on the World Wide Web, #255.]

- James, William. 1892 [1985]. In Gordon Allport (ed.), *Psychology: The Briefer Course*, University of Notre Dame Press, Notre Dame, IN.
- Kaye, Jonathan (ed.). 1991. *Semitic Studies in Honor of Wolf Leslau on the Occasion of his Eighty-Fifth Birthday*, Vol. 1, Otto Harrasowitz, Wiesbaden.
- Kenstowicz, Michael and Charles Pyle. 1973. 'On the Phonological Integrity of Geminate Clusters', in Michael Kenstowicz and Charles Kisseberth (eds.), *Issues in Phonological Theory*, Mouton, The Hague, pp. 27–43.
- Kenstowicz, Michael and Petros Degif Banksira. 1999. 'Reduplicative Identity in Chaha', *Linguistic Inquiry* 30, 573–586.
- Kim-Renaud, Young-Key. 1986. *Studies in Korean Linguistics*, Hanshin, Seoul.
- Kingston, John. 1985. *The Phonetics and Phonology of the Timing of Oral and Glottal Events*, unpublished Ph.D. dissertation, University of California, Berkeley.
- Kiparsky, Paul. 2000. 'Types of Front/Back Harmony', Handout of talk presented at Utrecht, The Netherlands. [June 2000.]
- Krakow, Rena A. 1999. 'Physiological Organization of Syllables: A Review', *Journal of Phonetics* 27, 23–54.
- Ladefoged, Peter. 1989. 'Representing Phonetic Structure', in *UCLA Working Papers in Linguistics*, Vol. 73, University of California, Los Angeles, pp. 1–79.
- Leben, William R. 1973. *Suprasegmental Phonology*, Ph.D. dissertation, MIT. [Published 1980, Garland, New York.]
- Liberman, Alvin M., Frank S. Cooper, Donald P. Shankweiler and Michael Studdert-Kennedy. 1967. 'Perception of the Speech Code', *Psychological Review* 74, 431–461.
- Lindau, Mona. 1978. 'Vowel Features', *Language* 54, 541–563.
- Löfqvist, Anders. 1997. 'Theories and Models of Speech Production', in William J. Hardcastle and John Laver (eds.), *The Handbook of Phonetic Sciences*, Blackwell, Oxford, pp. 405–426.
- Maddieson, Ian. 1985. 'Phonetic Cues to Syllabification', in Victoria A. Fromkin (ed.), *Phonetic Linguistics: Essays in Honor of Peter Ladefoged*, Academic Press, Orlando, FL, pp. 203–222.
- Maddieson, Ian. 1997. 'Phonetic Universals', in William J. Hardcastle and John Laver (eds.), *The Handbook of Phonetic Sciences*, Blackwell, Oxford, pp. 619–639.
- Matteson, Esther and Kenneth I. Pike. 1958. 'Non-Phonemic Transition Voids in Piro (Arawak)', *Miscellanea Phonetica* 3, 22–30.
- Mattingly, Ignatius G. 1981. 'Phonetic Representation and Speech Synthesis by Rule', in T. Myers, J. Laver and J. Anderson (eds.), *The Cognitive Representation of Speech*, North Holland, Amsterdam, pp. 415–420.
- McCarthy, John J. 1979. *Formal Problems in Semitic Phonology and Morphology*, Ph.D. dissertation, MIT. [Published 1985, Garland, New York.]
- McCarthy, John J. 1986. 'OCP Effects: Gemination and Antigemination', *Linguistic Inquiry* 17, 207–263.
- McCarthy, John J. 1988. 'Feature Geometry and Dependency: A Review', *Phonetica* 45, 84–108.
- McCarthy, John J. and Alan Prince. 1993. 'Generalized Alignment', in Geert Booij and Jan van Marle (eds.), *Yearbook of Morphology*, Kluwer, Dordrecht, pp. 79–153.
- McCarthy, John J. and Alan Prince. 1994. 'The Emergence of the Unmarked: Optimality in Prosodic Morphology', in Mercè González (ed.), *Proceedings of NELS 24*, GLSA, University of Massachusetts, Amherst, pp. 333–379.
- McCarthy, John J. and Alan Prince. 1995a. 'Prosodic Morphology', in Goldsmith (1995), pp. 318–366.

- McCarthy, John J. and Alan Prince. 1995b. 'Faithfulness and Reduplicative Identity', in Jill Beckman, Suzanne Urbanczyk and Laura Walsh (eds.), *University of Massachusetts Occasional Papers 18*, GLSA, University of Massachusetts, Amherst, pp. 249–384.
- McCawley, James D. 1972. 'The Role of a System of Phonological Features in a Theory of Language', in V. Makkai (ed.), *Phonological Theory*, Holt, Rinehart and Winston, New York, pp. 522–528.
- Mester, Armin. 1986. *Studies in Tier Structure*, Ph.D. dissertation, University of Massachusetts, Amherst. [Published 1988, Garland, New York.]
- Öhman, Sven. 1966. 'Coarticulation in VCV Utterances: Spectrographic Measurements', *Journal of the Acoustical Society of America* **39**, 151–168.
- Padgett, Jaye. 1992. 'OCP Subsidiary Features', in *Proceedings of NELS 22*, GLSA, Department of Linguistics, University of Massachusetts, Amherst, pp. 335–346.
- Padgett, Jaye. 1997. 'Partial Class Behavior and Nasal Place Assimilation', in Keiichiro Suzuki and Dirk Elzinga (eds.), *Proceedings of the 1995 Southwestern Workshop on Optimality Theory (SWOT)*, Coyote Working Papers, University of Arizona, Tucson, pp. unknown.
- Perkell, Joseph S. 1997. 'Articulatory Processes', in William J. Hardcastle and John Laver (eds.), *The Handbook of Phonetic Sciences*, Blackwell, Oxford, pp. 333–370.
- Pierrehumbert, Janet. 1993. 'Dissimilarity in the Arabic Verbal Roots', in *Proceedings of NELS 23*, GLSA, University of Massachusetts, Amherst, pp. 367–381.
- Port, Robert F. and Timothy van Gelder. 1995. *Mind as Motion*, MIT Press, Cambridge, MA.
- Port, Robert F. Fred Cummins and J. Devin McAuley. 1995. 'Naive Time, Temporal Patterns, and Human Audition', in Port and van Gelder (1995), pp. 339–372.
- Prince, Alan and Paul Smolensky. 1993. *Optimality Theory: Constraint Interaction in Generative Grammar*, unpublished manuscript, Rutgers University and University of Colorado.
- Prunet, Jean-François and Degif Petros. 1996. 'L'interaction entre Schèmes et Racines en Chaha', in Jacqueline Lecarme, Jean Lowenstamm and Ur Shlonsky (eds.), *Studies in Afroasiatic Grammar*, Papers from the Second Conference on Afroasiatic Languages [Sophia, Antipolis 1994], Holland Academic Graphics, The Hague, pp. 302–336.
- Rose, Sharon. 2000. 'Rethinking Geminates, Long-Distance Geminates, and the OCP', *Linguistic Inquiry* **31**, 85–122.
- Rubin, Philip E., Tom Baer and Paul Mermelstein. 1981. 'An Articulatory Synthesizer for Perceptual Research', *Journal of the Acoustical Society of America* **70**, 321–328.
- Sagey, Elizabeth. 1986. *The Representation of Features and Relations in Non-Linear Phonology*, Ph.D. dissertation, MIT. [Published 1991, Garland, New York.]
- Saltzman, Elliot. 1995. 'Dynamics and Coordinate Systems in Skilled Sensorimotor Activity', in Port and van Gelder (1995), pp. 149–174.
- Schein, Barry and Donca Steriade. 1986. 'On Geminates', *Linguistic Inquiry* **17**, 691–744.
- Selkirk, Elizabeth C. 1982. 'The Syllable', in Harry van der Hulst and Norval Smith (eds.), *The Structure of Phonological Representations*, Vol. 2, Foris, Dordrecht, pp. 337–383.
- Selkirk, Elizabeth C. 1993. 'Labial Relations', unpublished manuscript, University of Massachusetts, Amherst.
- Silverman, Daniel. 1995. *Phasing and Recoverability*, Ph.D. dissertation, UCLA. [Published 1997, Garland, New York.]
- Smith, Caroline L. 1991. 'The Timing of Vowel and Consonant Gestures in Italian and Japanese', in *Actes du XII<sup>e</sup>ème Congrès International des Sciences Phonétiques, Aix-en-Provence, France*, Vol. 4, pp. 234–237.

- Smith, Caroline L. 1993. 'Prosodic Patterns in the Coordination of Consonant and Vowel Gestures', in Bruce A. Connel and Amalia Arvaniti (eds.), *Papers in Laboratory Phonology IV: Phonology and Phonetic Evidence*, Cambridge University Press, Cambridge, pp. 205–222.
- Smolensky, Paul. 1993. 'Harmony, Markedness, and Phonological Activity', paper presented at the Rutgers University Optimality Workshop I, New Brunswick, NJ. [Version dated April 8, 1994.]
- Smolensky, Paul. 1995. 'On the Internal Structure of the Constraint Component *Con* of UG', handout of talk presented at UCLA, April 7, 1995.
- Smolensky, Paul. 1997. 'Constraint Interaction in Generative Grammar II: Local Conjunction (or, Random Rules in Universal Grammar)', paper presented at the Hopkins Optimality Theory Workshop, University of Maryland Mayfest, Baltimore.
- Steriade, Donca. 1982. *Greek Prosodies and the Nature of Syllabification*, unpublished Ph.D. dissertation, MIT.
- Steriade, Donca. 1993. 'Closure, Release, and Nasal Contours', in Marie K. Huffman and Rena A. Krakow (eds.), *Phonetics and Phonology 5: Nasals, Nasalization, and the Velum*, Academic Press, New York, pp. 401–470.
- Steriade, Donca. 1994. 'Complex Onsets as Single Segments: The Mazateco Pattern', in Jennifer Cole and Charles Kisseberth (eds.), *Perspectives in Phonology*, CSLI, Stanford, pp. 203–291.
- Turvey, Michael T. 1990. 'Coordination', *American Psychologist* **45**, 938–953.
- Ussishkin, Adam. 1999. 'The Inadequacy of the Consonantal Root: Modern Hebrew Denominal Verbs and Output-Output Correspondence', *Phonology* **16**, 401–442.
- Winfrey, Arthur T. 1980. *The Geometry of Biological Time*, Springer-Verlag, New York.
- Yip, Moira. 1988. 'Template Morphology and the Direction of Association', *NLLT* **6**, 551–577.
- Yip, Moira. 1989. 'Feature Geometry and Cooccurrence Restrictions', *Phonology* **6**, 349–374.

Received 30 June 2000

Revised 29 May 2001

Department of Linguistics  
New York University  
719 Broadway, Room 501  
New York, NY 10003  
USA

and

Haskins Laboratories  
270 Crown Street  
New Haven, CT 06511  
USA  
<adamantios.gafos@nyu.edu>

